

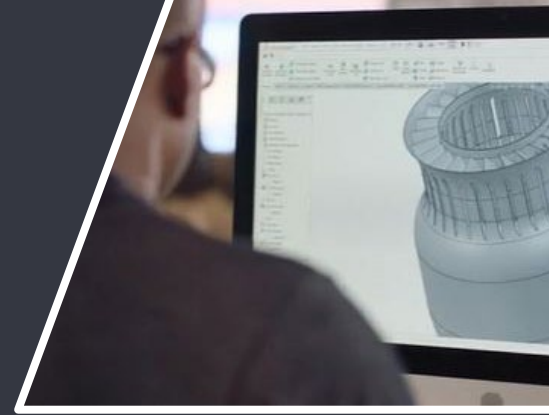

Definitive Guide to CNC Machining

Explore Process, Part Design, Materials,
and More for Subtractive Manufacturing



Contents

04 Optimizing Part Design for Machining

07 Designing for CNC Turning

10 Material Selection

14 Understanding Tolerances

17 Mistakes to Avoid

20 Threading Considerations

25 Post-processing Options

29 Complex Features

32 High-volume Machining

35 Why Protolabs for CNC Machining



Upload a Part!

Get an online quote with design for machinability analysis today.

Introduction

It was a simple and predictable idea that has forever changed how parts are manufactured. When modern computer-based control of machines was developed in 1949 by James Parsons at the Massachusetts Institute of Technology, the aim was to make aircraft parts that had consistency and durability. It was kind of clunky (are any version 1.0 tools perfect?) and used the technology of the day—punched paper tape—to convey model information to the machine, but it did what it set out to do.

Today, we've moved well past spools of punched paper tape. In modern digital manufacturing, CNC machining is part of a digital thread that takes customer-uploaded 3D CAD models and runs them through a design for manufacturability (DFM) evaluation. Once any issues are fixed in the CAD model, the digital file is translated into G-code, which tells the machine how to cut away metal or plastic material to define the desired shape of the model as an actual 3D object.

On some of today's mills, the machining process can take place on five different axes without removing and restaging the part in a fixture, making for faster, more accurate output. And hey—don't forget about CNC turning, which uses your 3D CAD models to create cylindrical parts. Turning on a high-speed lathe is basically the same idea as cutting away slivers of wood from a maple log as it spins on its long axis, ultimately making a baseball bat. It takes time to do it right, but we mill and turn parts 24/7.

This guide offers a comprehensive look at CNC machining, from milling to turning and prototype to production. It offers design dos and don'ts and lists materials you'll want to know more about to help you create the best parts.





Optimizing Part Design for Machining

Manufacturing prototypes and production parts quickly and cost-efficiently is often a balancing act of quick-turn CNC machining capabilities and an optimized part designed for those capabilities.



To fully optimize your design for machining, you should consider:

- ▶ Hole depths and diameters
- ▶ Size and types of thread
- ▶ Text on parts
- ▶ Wall heights and feature widths
- ▶ Live-tool lathes
- ▶ Multi-axis milling

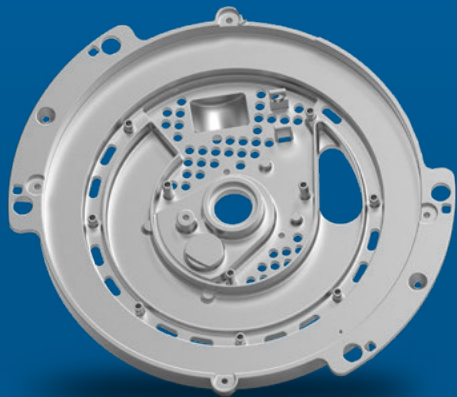

CNC Machining is a Subtractive Process

You start with a particular metal or plastic—in block or rod form—and remove material until you've achieved the desired geometries, based on your CAD model. But let's think about the complexities of that. In the wink of an eye, just the slightest miscalculation in your milling angle or in the original design could send your part into the recycling bin (Yes, we recycle!). However, it's not just about how you cut something. You also have to think about the properties of the [material](#) to ensure that it can endure the incredibly fast rotations of the tool that mills it or trims it off on a lathe. In the end, it's kind of like sculpting, but with no human hands involved in removal of material.

Manufacturing prototypes and production parts fast and cost-efficiently is a balancing act of automated [CNC machining capabilities](#) and an optimized part designed for those capabilities. So, there are a handful of important considerations when designing parts for Protolabs' milling and turning processes that can accelerate production time while reducing costs.

1 The 'Hole' Truth

Anyone who has spent more than five minutes in a shop knows what a drill bit looks like and what it does. For the most part, however, holes at Protolabs are machined with an endmill, rather than drilled. This machining method provides great flexibility in terms of the hole sizes available with a given tool and offers better surface finish than what you get with a drill. It also allows us to use the same tool for machining slots and pockets, reducing cycle time and part cost. The only downside is that holes much more than six diameters deep become a challenge due to an endmill's limited length and may require machining from both sides of the part, which adds production time.

2 Threading Right

Drilling and thread-making go hand in hand. Many shops use taps to cut internal threads. Taps look like a screw with teeth and are threaded into a previously drilled hole. Protolabs takes a more modern approach to thread-making, using a thread mill to interpolate the thread profile. This creates an accurate thread. Best of all, you can use a single-size mill to cut any thread size that shares that pitch (the number of threads per inch)—saving you time in setup and production. Because of this, UNC and UNF threads from #2 up to 0.50 in., and metric threads from M2 to M12 are possible, all within a single toolset. We'll take a closer look at threads on page 20.

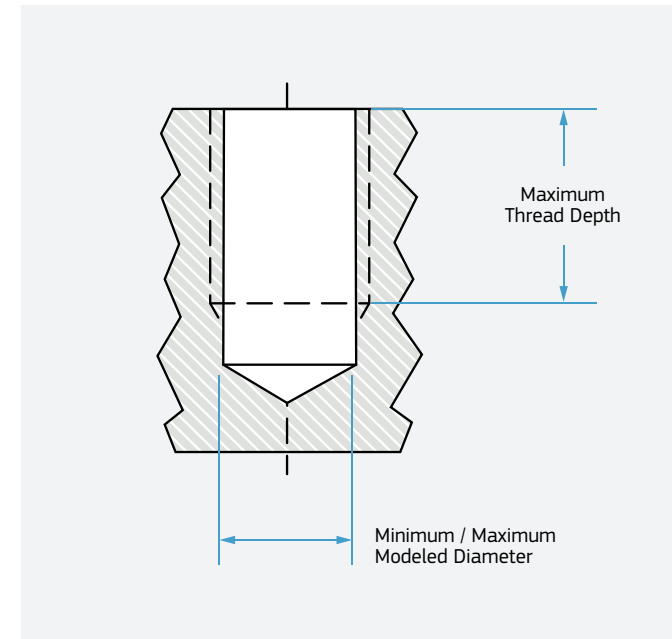

3 Be Careful Texting

Sometimes, milling a part number, description, or logo is necessary for your part design. Machining text, though, also adds cost. And the smaller the text, the higher the cost. That's because the very small endmills that cut the text operate at a relatively slower speed, increasing run time on your part and therefore your final cost. You do have options, however. Our toolsets are capable of machining pretty much any text required, provided the spacing between individual characters and the stroke used to cut them measures at least 0.020 in. (0.5mm). Also, text should be recessed rather than raised. For best effect, use 20-point or larger fonts such as Arial, Helvetica, Verdana, or a similar sans-serif font.

4 Tall Walls and Tiny Features

Our toolsets contain carbide cutting tools. This super rigid material offers maximum tool life and productivity with minimal deflection. But even the strongest tools deflect, as do the metals and especially plastics being machined. Because of this, wall heights and feature sizes are very dependent on both the individual part geometry and the toolset being used. For instance, the minimum feature thickness we recommend is 0.020 in. (0.5mm) and the maximum feature depth is 2 in. (51mm), but that doesn't necessarily mean you can design a ribbed heatsink using those dimensions.

5 Live Tool Lathes

Aside from extensive milling capabilities, we offer live-tool CNC turning, too. The toolsets used on these machines are similar to the ones on our machining centers, except we do not turn plastic parts at this time. That means off-center holes, slots, flats, and other features can be machined parallel or perpendicular (axial or radial) to the long axis of the turned workpiece (its Z-axis) and will typically follow the same design rules as those applied to the orthogonal parts made using our machining centers. The difference here is in the shape of the raw material rather than the toolset itself. Turned parts such as shafts and pistons start out as cylindrical stock, while milled parts—manifolds, instrument cases, and valve covers, for example—typically don't. They use square or rectangular blocks instead. Lots more about turning coming right up!



Live Tool Lathes: The part above was made with a CNC lathe using live tooling.

6 3-Axis and 5-Axis Machining

We use two distinct flavors of milling. With 3-axis machining, the workpiece is gripped from the bottom of the raw material blank while the part features are cut from up to 6 orthogonal sides. With parts larger than 10 in. by 7 in. (254mm by 178mm), only the top and bottom can be machined: no side setups! With 5-axis indexed milling, however, machining from any number of non-orthogonal sides is possible.

In either case, the toolsets used are identical. What's different is the raw material. As with our lathes, rod stock is used for 5-axis milled parts, which presents some interesting mathematical discussions about the size, geometry, and positioning of the part within that raw material volume. For some examples of this, you can stare at the accompanying diagrams for a while, or just upload your part model online at [protolabs.com](https://www.protolabs.com).

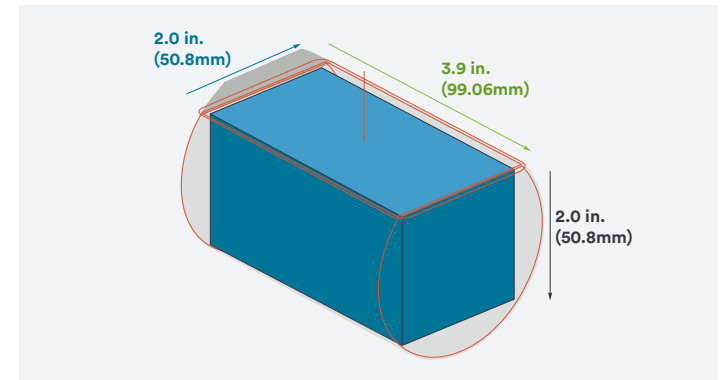

3-Axis and 5-Axis Machining: This illustration shows how a part using 5-axis machining fits within a block of material using the maximum part extents.



Designing for CNC Turning

It was once a no-brainer. Round parts were turned on lathes; non-round parts were machined on mills. With the advent of CNC machining centers, which interpolate round part features with ease, the line between the two machining processes has become blurred.

The situation grew even more confusing when CNC lathes attained live-tool capability. Operations that were once the exclusive domain of the milling department were now coming off the lathe complete. As a result, deciding which machine is the best fit for producing any given part has become more complicated.

Our turning operations offer you a variety of materials to work with, such as aluminum, brass, low carbon steel, stainless steel, steel alloy (4140), and titanium. Protolabs does not currently turn plastics.



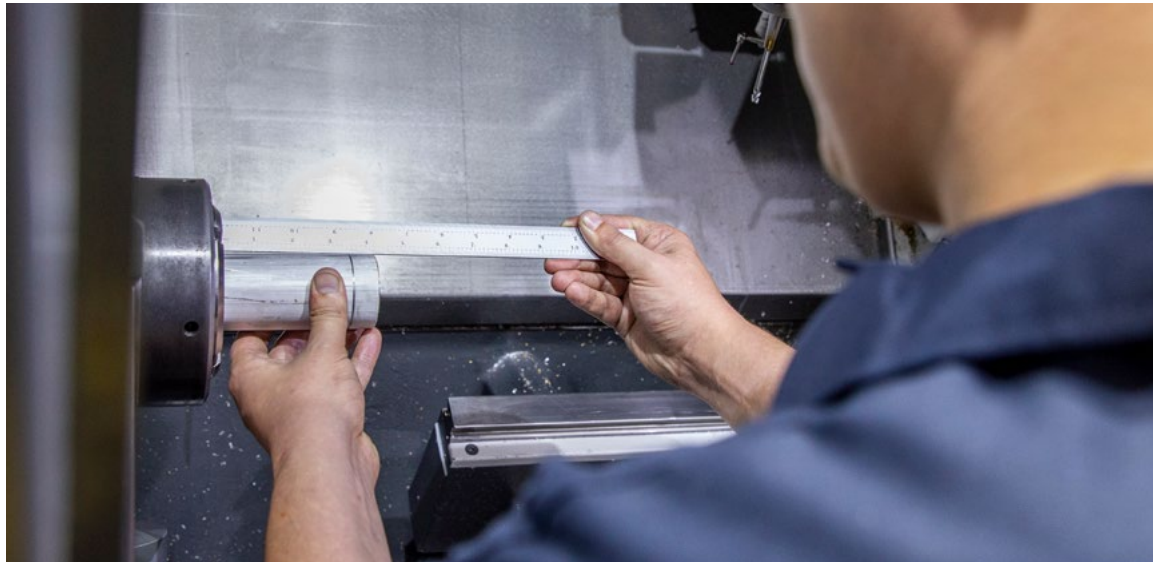

Candidates for Lathe

Some parts are obvious lathe candidates. Consider the piston for a spool valve, or a hydraulic fitting. The cylindrical symmetry of these components, coupled with complex external geometry and challenging internal features, makes them perfect for the turning department.

Conversely, the rectangular valve body that mates with those turned parts, with its large, milled surfaces, detailed pockets, and intersecting bores will never be spun on a lathe, no matter how live-tool capable that machine may be.

These are some of the reasons why our CNC machining service has turned to, well, turning. By adding live-tool (end mill) equipped CNC turning centers to our already extensive 3-axis milling service, we're able to improve surface finish on cylindrical features and typically do it at a lower price for customers. A lathe also makes more efficient the manufacture of those parts that may skate on the edge of our milling capabilities. And if the goal is eventual low-volume production, turned parts are good candidates.

Turning parts can offer several advantages over milling. As implied previously, long length to diameter ratios on pistons and shafts are better suited for the lathe.

Everyday Examples

If you're still unsure about what parts are lathe-worthy, consider a few household objects. A pint glass, for example, with its smooth, regular shape and length several times greater than the outside diameter is a straightforward exercise on a lathe. Not so on a machining center. A coffee cup, on the other hand, with its jutting handle and finger-ready hole, is impossible to turn.



Those 3-lb. dumbbells collecting dust in the closet could be turned fairly easily on a lathe. The wide, relatively deep recessed area where your hand grips the bar can be turned with a simple grooving routine, a feature that would be murderous to cut on a milling machine.



A small teacup saucer could go either way. Interpolating the concentric ridges and curved surfaces can be done on a mill or a lathe, requiring nothing more than accurate G-code and a suitable cutter. That said, it would almost certainly be faster to turn the saucer, and far more efficient in terms of material use.



How about a hose barb for the sprinkler? The v-shaped grooves would require a special cutter on a machining center, whereas a lathe can use a standard turning tool. The same holds true with a replacement wheel for a barbecue grill, although milling those little mag wheel-like cutouts on the face would be challenging or outright impossible on most turning machines.



Soup cans and salt shakers, water bottles and flower pots—these shapes are what lathes are all about. Milk cartons and picture frames? Not so much.



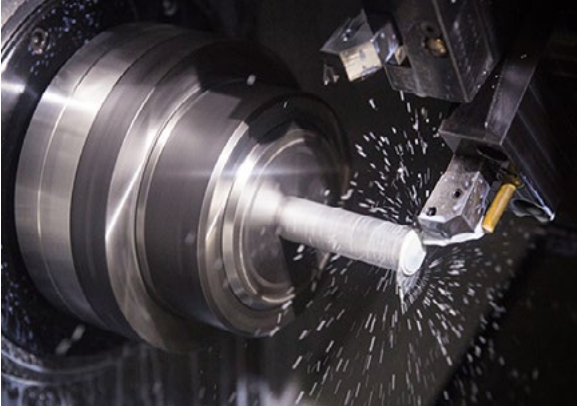

Lathe Capabilities

When it comes to size, we'll tackle parts up to 3.95 in. (100.33mm) in diameter by 9 in. (228mm) long, and as small as 0.16 in. (4.07mm) diameter by 0.050 in. (1.27mm) long. Sharp conical points are okay, as long as the angle is greater than 30 degrees. No promises on ballpoint pen prototypes, or models of soda straws.

As mentioned earlier, our new lathes have milling capability. Drilling a side hole or milling a flat is well within their means if that feature is parallel or perpendicular to the long axis of the part. Any milled grooves should be wider than 0.047 in. (1.2mm), but because our lathes are equipped with a Y-axis, we can machine slots or holes off-center (within reason).

Need your company's name engraved on the parts? With a lathe, raised text is best, but we can machine most any lettering if the line width and character spacing measures at least 0.020 in. (0.5mm) across. Small holes don't scare us off, nor do threads. In fact, we'll drill radial holes down to 0.080 in. (2mm) and axial holes half that size. Likewise, we support a range of internal and external UNC, UNF, and metric threads.

You're likely to notice that turned surfaces are smoother and rounder than their milled counterparts. Milled features may have visible tool marks, but we can bead blast these surfaces to give them a matte finish and knock down any small burrs that remain after the machining process. We'll talk about finishing options later in this guide.

We've found over the years that making round parts out of square or rectangular stock can leave a few things to be desired. Milling away the square corners to get to the round part underneath takes longer than turning it from bar stock. It also creates more material waste. Turning those parts in a machine designed for such work is certain to be a win-win for everyone. To learn more about turning at Protolabs, check our process and guidelines page or upload your part now to see if it qualifies.



Getting a Turning Quote

Like all machined parts, the process begins with entering your CAD model into our automated quoting system. Our software will determine the best machining method (milling or turning) for each material. You can sometimes override this decision when you configure the quote. Pricing and capabilities vary based on which process you choose. When you configure the quote, select the machining process that best meets your needs after weighing these factors. If a part does not qualify to be turned in a particular material, this option will not be available in the quote for that material. [Give it a try!](#)



Material Selection

The raw metal or plastic you choose to use for your parts is just as important as how the parts are machined. Selecting the wrong material could unnecessarily balloon part costs. For instance, superalloy and darling of the aerospace world, titanium, is hard to machine and parts made of it will almost certainly cost more than ones made of aluminum or stainless steel. Often that is also the case with plastics PEI and PEEK. The point? If it's not truly needed, opt for a more inexpensive material.



Part Design Priorities



Environmental

This covers heat and cold resistance, flame retardance, and UV- and chemical-tolerance. Do you need food-grade or medical-grade materials for your parts to endure an autoclave's extreme heat or harsh chemical sterilization?



Electrical

A part may need to conduct, insulate, or dissipate static. In any of those cases, choosing the right metal or plastic resin will be critical.



Mechanical

A part may need to fall anywhere on a continuum from rigid to flexible. It may require tensile strength, compressive strength, or be impact resistant. Some parts may have to resist wear or provide lubricity to function, as does a bearing.



Cosmetic

Typically, cosmetics are a secondary consideration, but they can be essential. Some materials offer transparency or translucency, and plastics can come in a variety of colors, while metals can be colored in finishing. Plus, don't forget textural finishes, which vary from non-slip to high polish.



Size

While machining can produce parts in a range of sizes, part size can be limited by the maximum available size of a particular stock material.



Cost

Cost can be an important factor that will typically fall somewhere between the must-haves and the nice-to-haves.

Some technical considerations that will help you choose a suitable material for your part's application include specific measurements such as tensile strength, heat deflection, and overall hardness. Find these specs in our [materials for machining](#) data sheets.

Ready to compare? Here are some of the more common materials used for machined parts, along with their key properties. The list isn't exhaustive—we carry more than 40 different metals and plastics for milling and 10 metals for turning—but it basically hits the highlights.

Comparing Machining Materials

Metals	Electrical Conductivity	Impact Resistance	Chemical Resistance	Wear/Abrasion Resistance	Temperature Resistance	Moisture Resistance
Aluminum	X		X		X	X
Cobalt Chrome		X	X	X	X	X
Inconel		X	X	X	X	X
Stainless Steel	some	use 4140	X	X	X	X
Steel	X	X		some		
Titanium		X	X	X	X	X

Plastics	Impact Resistance	Chemical Resistance	Wear/Abrasion Resistance	Temperature	Moisture Resistance	Transparency
ABS	X		X		X	some
Acetal	X			X	X	
Delrin		X	X	X	X	
Nylon			X			
PC	X		X	X	X	X
PEEK	X	X	X	X	X	
PEI	X	X	X	X	X	amber-shaded

Metals

Aluminum

A broad assortment of aluminum alloys exists, but the most common are 6061-T6 (considered a general-purpose alloy) or 7075-T6 (a favorite of the aerospace industry). Both are easy to machine, corrosion resistant, and exhibit high strength-to-weight ratios. Keep in mind that Protolabs offers traceable UT-tested aluminum for milled parts. It is identical to standard aluminum 6061-T6 but is ultrasonic tested and guaranteed to conform to ASTM B 594 and AMS- STD-2154 specifications.

Aluminum is suitable for airplane parts, computer components, cookware, architectural components, and more. Here's a quick comparison:

Aluminum 6061 vs. 7075

- ▶ 6061 offers excellent machinability, low cost, and versatility
- ▶ 7075 offers high strength, hardness, low weight, and heat tolerance

Stainless Steel

By adding a minimum of 10.5 percent chromium, reducing the carbon content to a maximum of 1.2 percent, and tossing in some alloying elements like nickel and molybdenum, metallurgists convert ordinary rust-prone steel into stainless steel, the corrosion-proof switch hitter of the manufacturing world. Stainless steels 303, 304, and 316L have a crystalline structure that make them non-magnetic, non-hardenable, ductile, and quite tough. 17-4 PH is favored for its excellent mechanical properties.

Steel

Often, this is the go-to metal for many applications, but of course, steel has its good and bad attributes:

- ▶ Steels generally cost less than stainless steels and superalloys.
- ▶ In the presence of air and humidity, all steels corrode.
- ▶ Most steels are quite machinable, with the exception of some tool steels.
- ▶ The lower the carbon content, the less hard steels can be made (indicated by the alloy's last two digits, as in 1018, 4340, or 8620, three common selections). That said, steel, and its cousin iron, are among the most used metals, with aluminum a close second.

Titanium

Titanium is extremely strong and boasts a high strength-to-weight ratio. It also has excellent corrosion resistance, high operating temperatures (up to 1,000°F) and is nontoxic. Another key benefit of titanium is its low thermal expansion and high melting point (~ 3,000°F). Often, you'll find titanium parts used in the aerospace, medical, military and marine industries.



Plastics

ABS

More affordable than comparable thermoplastics with superb mechanical properties like toughness, hardness, and rigidity. ABS has high impact resistance and surface hardness under high and low temperatures, terrific dimensional stability, and a higher heat deflection temperature than its thermoplastic counterparts.

Typical parts:

- ▶ Electronic housings
- ▶ Plumbing
- ▶ LEGO toys

Nylon

A go-to material choice for mechanical components that will experience wear and friction. As with PEEK and Delrin, sometimes it can be used as a metal replacement. We offer: Nylon 6 Light Blue, Nylon 6/6, Nylon 6/6 30% Glass-Filled Natural, Nylon 6 Black.

Typical parts:

- ▶ Gears and bearings
- ▶ Sprockets
- ▶ Sheaves

PEI (Ultem)

Another truly tough plastic choice, PEI offers high heat and impact resistance. Glass fiber is often added to enhance an already rugged product. You can even add lubricity (slipperiness), making it a great choice for ball bearings and pivot joints. We offer: Ultem 1000 and Ultem 2300 (30% Glass-Filled).

Typical parts:

- ▶ Medical and dental devices
- ▶ Automotive parts
- ▶ Electrical connectors
- ▶ Aerospace parts

Polycarbonate (PC)

An engineering plastic with excellent dimensional stability and good strength and stiffness. It's a go-to material for parts that need clarity and impact strength. We offer four grades of machined polycarbonate: Black, Clear, Translucent, 20% Glass-Filled.

Typical parts:

- ▶ Gears and rollers
- ▶ Internal mechanical parts
- ▶ Pumps
- ▶ Light bezels

Polyetheretherketone (PEEK)

The Superman of polymers, PEEK can replace metal in certain applications but prepare yourself for sticker shock. It typically costs five times more than other high-performance thermoplastics.

Typical parts:

- ▶ Bearings
- ▶ Thrust washers and seals
- ▶ Piston parts
- ▶ Semiconductor fabrication
- ▶ Pumps and compressor plate valves

POM (Delrin)

This acetal homopolymer has excellent durability and low moisture absorption. It's a good material option for mechanical components and industrial products and can sometimes replace metal. We offer four grades of delrin/acetal homopolymer.

Typical parts:

- ▶ Gears and bearings
- ▶ Sporting goods
- ▶ Electrical insulator parts
- ▶ Connectors and fittings

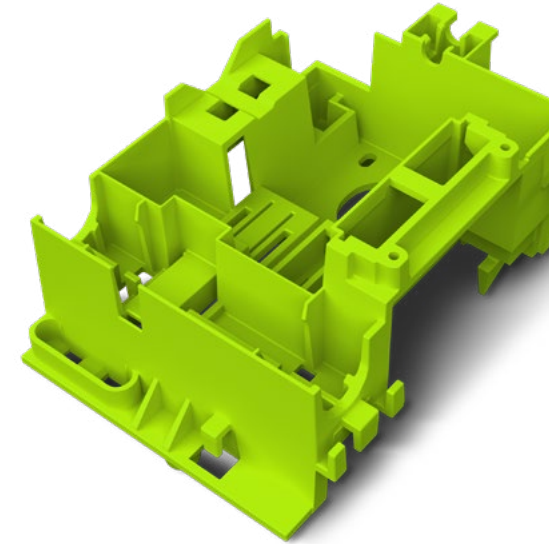

[Upload a Part!](#)

Get an online quote with design for machinability analysis today.



Understanding Tolerances

Tolerances represent the amount of variance you can expect when your parts are turned or machined. Essentially, they set the typical limits—plus or minus—on the accuracy of the features.



Working with Bilateral Tolerance

Be aware that these are bilateral tolerances. If expressed in unilateral terms, the standard tolerance would read $+0.000/-0.010$ in. (or $+0.010/-0.000$ in.) while a limit-based tolerance in our bracket example would be $1.005 / 0.995$ in.

All are acceptable, as are metric values, if you spell them out on the design. And to avoid confusion, please stick with the "three-place" dimensions and tolerances shown, avoiding the extra zero in 1.0000 or 0.2500 in. unless there's an overriding reason to do so.



Standardized Tolerances for CNC Machining

The standard prototype and production machining tolerance at Protolabs is ± 0.005 in. (0.13mm). This means any part feature's location, width, length, thickness, or diameter will not deviate by more than this amount from nominal. For example, the 1 in. (25.4mm)-wide bracket you're planning to order will measure between 0.995 and 1.005 in. (25.273 and 25.527mm) across, while the 0.25 in. (6.35mm) hole on one leg of that bracket will come in at 0.245 to 0.255 in. (6.223 to 6.477mm) diameter.

That's pretty close, but if you need greater accuracy, there's our standard precision or production machining tolerance of ± 0.002 in. (0.051mm). We're also able to hold ± 0.0005 in. (0.0127mm) on reamed holes, and ± 0.002 (0.051mm) on feature locations, provided those features are machined on the same side of the part. Depending on the part geometry and material, however, we can often achieve even greater accuracy, provided you make us aware of your requirements. For these and other exceptions, please be sure to note them on your part design when you upload the file(s) for quoting.

Surface Roughness Considerations for Machining Tolerances

There's more to part tolerancing than length, width, hole size, etc. There's also surface roughness, which in the standard offering is equal to $63 \mu\text{in.}$ for flat and perpendicular surfaces, and for curved surfaces, $125 \mu\text{in.}$ or better.

This is an adequate finish for most uses, but for cosmetic surfaces on metal parts, we're generally able to improve appearance through light bead blasting. If you need something smoother, note it on your design and we'll do our best to accommodate you.

One Step Beyond: Geometric Dimensioning and Tolerancing (GD&T)

Here's another possibility. We can accept GD&T tolerancing. This provides a deeper level of quality control that includes relationships between various part features as well as form and fit qualifiers. Here are a few of the more commonly used ones:

- ▶ **True position:** With GD&T, a hole's location is called out by its true position from a set of reference points, accompanied by the qualifiers MMC (maximum material condition) or LMC (least material condition).
- ▶ **Flatness:** Milled surfaces are generally quite flat, but due to internal material stress or clamping forces during the machining process, some warpage can occur once the part has been removed from the machine. This especially happens on thin-walled and plastic parts. A GD&T flatness tolerance controls this by defining two parallel planes within which a milled surface must lie.
- ▶ **Cylindricity:** This focuses on the roundness of a milled hole or a turned surface. However, using a ± 0.005 in. ($\pm 0.127\text{mm}$) tolerance, a 0.250 in. (6.35mm) hole could potentially be oblong, measuring 0.245 in. (6.223mm) one way and 0.255 in. (6.477mm) the other. Using cylindricity—defined as two concentric cylinders inside of which the machined hole must lie—we can eliminate this unlikely situation.
- ▶ **Concentricity:** The rings on a bullseye are concentric, just as the wheels on your car are concentric to the axle. If a drilled or reamed hole must run perfectly true to a coaxial counterbore or circular boss, your best bet is a concentricity callout.



► **Perpendicularity:** As its name implies, perpendicularity determines the maximum deviation of a horizontal machined surface to a nearby vertical surface. It can also be used to control the squareness of a turned shoulder to an adjacent diameter or the center axis of the part. There are additional GD&T dimensions you can include, including parallelism, straightness, profile, and angularity, all of which are spelled out in ASME Y14.5. As with any other non-standard tolerances, however, they must be called out in the design at the time of upload. Tolerancing with GD&T also means that projects will bypass our automated Protolabs quoting process and be rerouted to our myRapid quoting experience—our CNC machining high-precision/high-quantity option.

Why High-Precision, High-Quantity Machining?

So, what is the difference between our machining options? For starters, as noted above, a quote for high-precision, high-quantity machining is not automated as it is with our standard machining option, so the quote might take a day for human review. With high-precision machining, the finished part lead-time is also a little longer, with five to 10 days as standard. We require a 3D CAD model, along with a 2D drawing for GD&T tolerances. It could also mean that we go beyond our standard cutting tool set and use machining processes such as EDM hole popping, grinding, and boring to meet your part quality requirements.



Quality Control and Documentation Options

Upon request, we'll measure parts on one of our coordinate measuring machines (CMMs) and other metrology equipment. We will also work with you on the Production Part Approval Process (PPAP), provide a Certificate of Conformance (CoC) to your specifications, and provide First Article Inspections (FAIs), material certifications, and heat lot numbers.

Mistakes to Avoid

For all of the technology that makes one-day part turnaround possible, it is usually the human element that emerges as the culprit in recurring issues we see in parts designed for CNC machining.

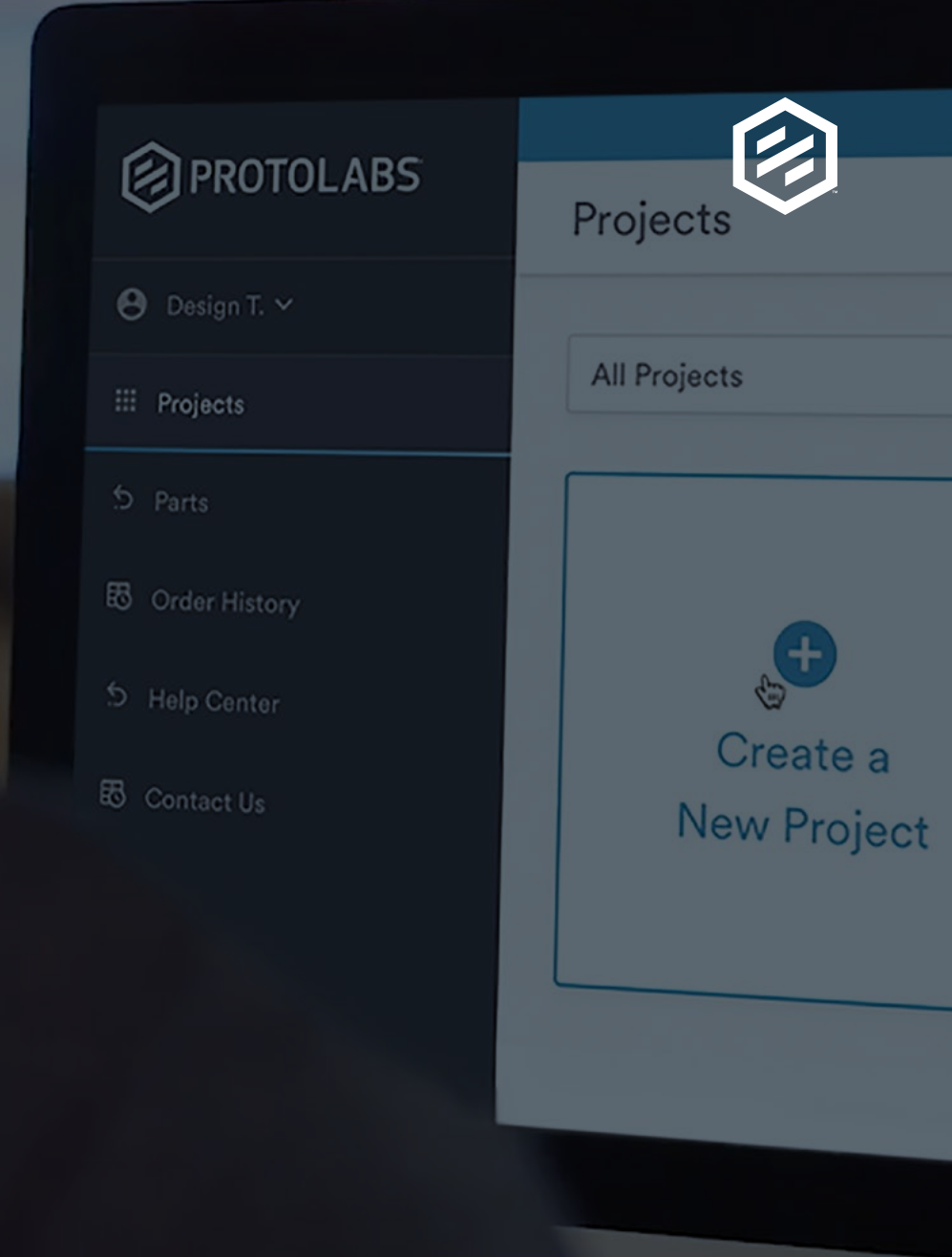

1 Avoid Features That Require Unnecessary Machining

One frequent mistake is designing a part with areas that don't need machine cutting. Such unnecessary machining adds to your part's run time—run time that's a key driver of your final production cost. Consider this example, where the design specifies a critical circular geometry needed for the part's application (see illustration). It calls for machining the square holes/features in the middle and then cutting away the surrounding material to reveal the finished part. That approach, however, adds significant run time to machine away the remaining material. In a simpler design (see illustration), the machine simply cuts the part from the block, eliminating the need for additional, wasteful machining of excess material altogether. The design change in this example cuts machine time nearly in half. Keep your design simple to avoid extra run time, pointless machining—and added cost.

2 Avoid Tall, Thin Walls

Wall features in part designs are generally tricky. As we mentioned earlier, cutting tools are incredibly rugged, but they (and the material) can still deflect during cutting due to the mill's rotational forces, resulting in issues such as an undesirable rippled surface and difficulty meeting part tolerances. Worse yet, walls can chip, bend, or break. Here are some other wall design specs to keep in mind:

- ▶ The taller your wall—our maximum is 2 in. (51mm)—the thicker it may need to be to increase the rigidity of the material.
- ▶ Thin walls of 0.020 in. (0.508mm) or less are subject to breaking during machining and may flex or warp afterwards.
- ▶ Try not to design walls too thick as the cutting tool usually is spinning at 10,000 to 15,000 rpm.
- ▶ A good rule of thumb for walls is a width-to-height ratio of 3:1.
- ▶ Adding some draft to a wall—an angle of 1, 2, or 3 degrees so that it tapers rather than standing vertical—could make machining it easier and leave less leftover material.

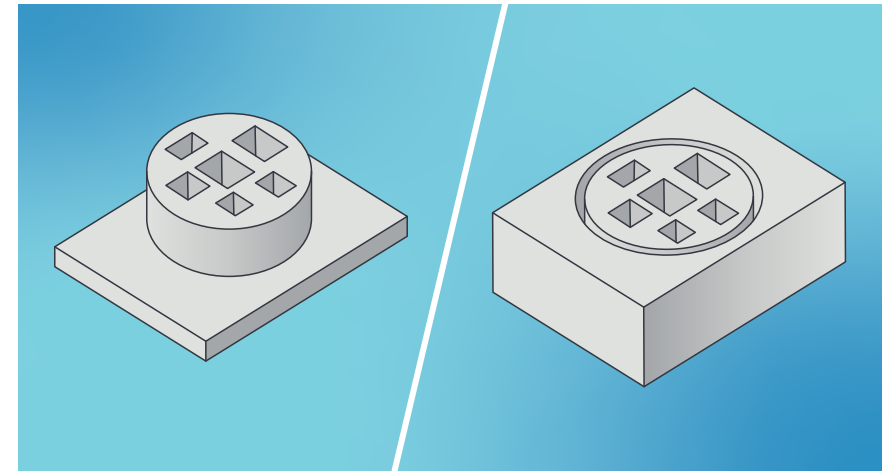

Avoid Unnecessarily Complex Designs: The design on the right will require significantly less milling time—saving you money.

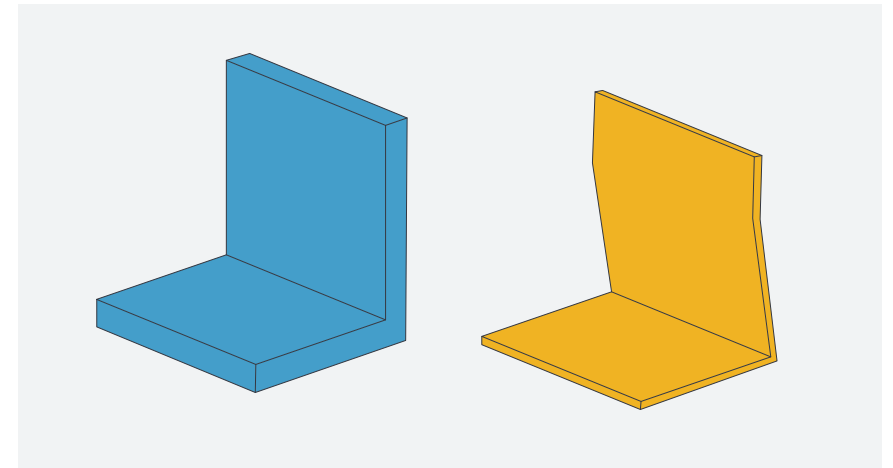

Avoid Unnecessarily Complex Designs: The design on the right will require significantly less milling time—saving you money.

3 Avoid Small Pocket Features You May Not Need

Some parts incorporate square corners or small internal corner pockets to reduce overall weight or to accept other pieces of an assembly. Internal, 90-degree corners and small pockets, however, are too small for our larger cutting tools. Creating those means picking away at the corner material with smaller and smaller tools. That could result in using six to eight different cutting tools. Those tool changes drive up run time—and you guessed it—your project’s cost. To avoid this, first determine how critical the pockets really are. If they are there only to reduce weight, revisit your design to avoid paying to machine material that doesn’t need to be cut. The larger the corner radius you design, the bigger the cutting tool we can use, and the less run time it will take.

4 Avoid Creating Holes That Can't Be Threaded

As we mentioned in the chapter on optimizing your designs, we can easily add threaded holes to your machined parts. But designing threads so that our quoting software will see them—and so they will get machined into your part—can be challenging. Our quick turn process has a static set of threads available. When our software analyzes your part, it looks for a hole diameter that will correspond to one of those threads. If you want a UNC or UNF #5-40 thread, for example, the software looks for a hole with a diameter that’s within the range for that thread. If the diameter isn’t within that range, you won’t be able to assign that thread to your part. This often is when customers call and when we refer them to our quick-reference [Threaded Hole Guidelines](#) webpage. There, you’ll find the types of threads we have available. Click on a particular thread to go to a chart with the range of hole diameters to choose for it. Choosing a diameter that’s 75 percent of the hole drill size—each chart includes that dimension for every thread—will always work. As you’re designing your part, go ahead and use your CAD software’s thread wizard—most customers do. But confirm with our charts that the wizard is outputting a hole diameter that works with our software. Learn more considerations for thread design [here](#).

5 Reconsider Machining Parts That Will Eventually Be Molded

We often see designs for injection-molded parts uploaded to our machining service for prototyping before buying a mold. But each process has different design requirements, and the results can differ. A thick machined feature may suffer sink, warp, porosity, or other problems when molded. A well-designed molded part with ribs, pockets, and other features will require prolonged run time to machine. The point here is part designs are typically optimized for their manufacturing process. Talk to our team first for advice on how to modify your design for a molded part for machining, or simply prototype your parts in their final production process— injection molding. At Protolabs, the initial cost investment for prototype tooling is very low.





Threading Considerations

Incorporating threads in your parts can sometimes be the ultimate undoing of your assemblies. There are a lot of design rules, and you need precision to manufacture threads and ensure that they work right.



External vs. Internal Threading

This is pretty basic, but important. An easy way to remember this difference is that you'll find external threading on screws and bolts—it's external to the hardware. Internal threads reside inside the main part. They accept, and lock in, screw and bolt threads.

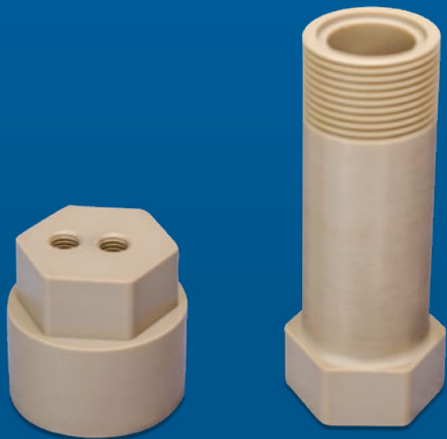

Thread Pitch

When we talk about threads on bolts and screws, it's not a one-size-fits-all kind of scenario. In addition to metric threads, there are three primary kinds of imperial measure threads that are part of the Unified Thread Series.

- ▶ UNC (coarse pitch): 20 threads per inch (tpi)
- ▶ UNF (fine pitch): 28 tpi
- ▶ UNEF (extra fine pitch): 32 tpi

Note that adding UNEF thread pitch requires our precision machining service, accessible via our quoting system. For example, if you want to incorporate a #4-40 screw, you know that a #4 screw—which has a thread diameter of 0.11 in. (2.794mm) has 40 threads per inch, meaning extra fine pitch.

The good news is that when you use our system to assign a particular type of screw to a hole, the desired thread pitch comes along for the ride. Less worries are always good, right?

Where Can I Place a Thread?

Really, a thread can be placed almost anywhere that makes sense for the turned or milled part and your assembly's needs. As long as the area in which the thread will go is accessible to our equipment, you're good to go. If there are obstructions to prevent it, our design analysis software will let you know.

Even though it seems like there aren't a lot of placement restrictions when it comes to threading, the depth of an internal thread is important to consider. If the thread depth exceeds the maximum depth for the tooling, we may have to drill through from both sides of the hole to complete the process. When that happens, it's important to know that your threads will not be continuous from one end to the other, but there are options we'll go over in the next section.

With turned parts, there are three types of holes you can use to accommodate internal threads:

1. On-axis: holes that go straight through the center of a turned part, starting at one end
2. Axial: holes that start at one end of a part, but don't go perfectly through the center
3. Radial: holes that pierce through the exterior arc of a turned part

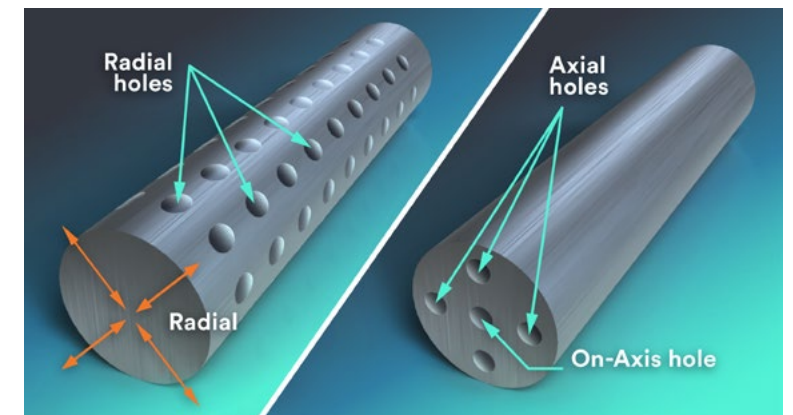

Three Types of Holes For Threaded Parts: On-axis, Axial, and Radial.

Internal Threads

Internal threads are machined using a single-lip threading tool—not a traditional threading tap. On parts with internal-hole features in need of threading, the actual threads need to be removed from your CAD model, leaving only the pilot diameter. Protolabs' design analysis software recognizes a hole for threading if:

- ▶ it falls within the diameter range for the desired thread and,
- ▶ is on one of the three cardinal axes for milling or,
- ▶ is perpendicular to the axis of revolution for turning.

We supports right-hand threaded holes on machined parts for UNC and UNF threads ranging from a #2 and up to 1/2 in. (12.7mm) metric threads are also available, ranging from M2 to M12. Location and method of manufacturing may limit some threads from becoming eligible. We also offer NPT threads for aluminum, copper, and brass parts.

In machining internal threaded holes, a hole may be longer than what our threading tools are able to reach. In this case, you have a few options depending on your needs:

- ▶ With a long through hole that exceeds the maximum reach, select the hole from the side that you anticipate the screw to be started from (see image 1 in three-panel illustration). If your screw is required to pass the entire way through the part, you would also have to pass a tap through the hole (in a secondary process) to complete it.
- ▶ You can also select both sides of the feature to be threaded (see image 2 in illustration) but notice the maximum thread depths as they overlap with each other in the hole. This raises concern with threading the features from both sides, because you risk cross-threading and a screw may not pass all the way through the part cleanly. As long as the threads don't intersect (see image 3), selecting threads from both sides is typically fine.

If your designs instruct your manufacturer to mill out a pilot hole that's the same diameter as the major (wider) thread, the hardware you use will never fit properly in the hole. Instead, the screw will likely spin around endlessly in the hole. Save yourself some trouble: Make sure that any threaded feature's pilot hole reflects the minor diameter of your thread. Most CAD programs have built-in wizards to help with this process.

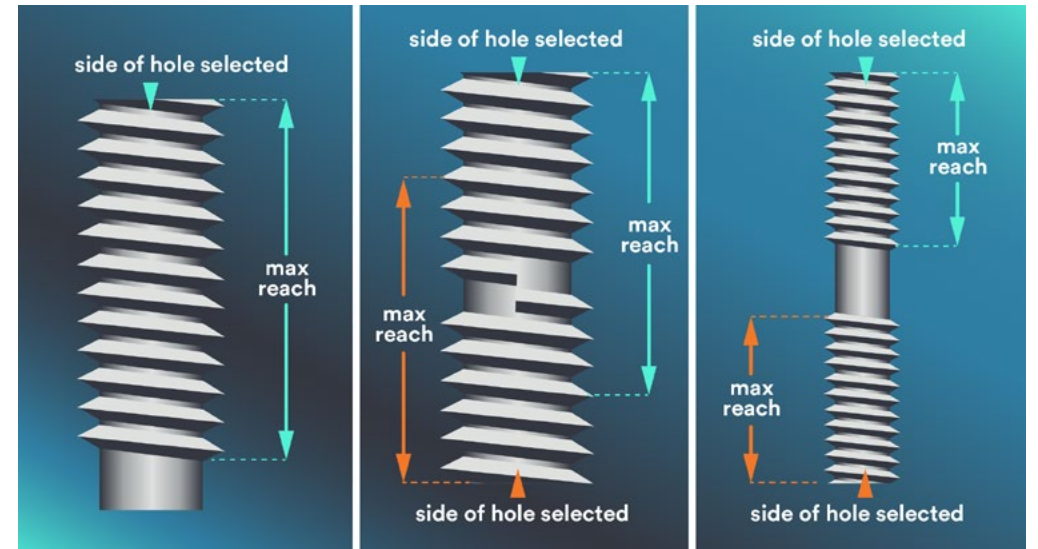

From Left to Right: Images 1, 2, and 3 depict three methods of approaching maximum thread depths.

Know Your Diameters

One important consideration with internal threads has to do with the various diameters involved with creating threads. There are three:

1. The major (wide) thread
2. Minor (narrow) thread
3. Diameter of the pilot hole for your threaded feature

External Threads

The great thing about external threads on turned parts is that the thread can extend the length of the part, if your parts qualify for turning. We use a custom threading tool with a selection of thread sizes, depths, and placements within the part geometry. However, our advanced turning process offers external threads on the centerline of the part, and live tooling that allows threading of internal holes, if they follow similar guidelines as milling. We offer external threading for on-axis, axial, and radial holes. Milling external threads is done in two stages. The first set of threads go halfway around your turned part, followed by thread milling on the other side. The two sides meet along the centerline of your part. This process works well for 1/2-inch threads, but we do advise chasing the threads to remove excess material or smooth out mismatches in threading.

Just like internal threads, external thread design requires that the thread be removed from the CAD model for our software to recognize it. Additionally, please model your external threads for milling; don't model them for turning. After you receive your quote for turning, you will have the ability to select the appropriate thread size.

Alternatives to Threading

For most metal parts, threading is a great way to achieve a strong bond between elements of your assembly. But sometimes that's not enough, especially with parts made from weaker materials, such as plastics and aluminum. That's where inserts come in handy. Consider incorporating special coil inserts in plastic parts to ensure longer part life. These rugged little disks allow you to get strong threading, even on weaker material. Essentially, you'll design a hole in the desired location, and you can add the inserts to your parts later. We will mill out the hole to your specification and prep it to receive your insert. Protolabs is optimized for HeliCoil brand inserts and we recognize standard sizes and lengths.

Designing Smaller External Threads

Protolabs' extensive machining capabilities include 5-axis mills, which allow for simultaneous movement on up to five machine axes while the cutting tool is engaged in the workpiece. Complex "swept surface" parts like boat propellers, orthopedic implants, and turbine blades can now be manufactured with fewer setups.



How to Incorporate Threading into Your Quotes

In our quoting system—adding threaded features is pretty simple. Our software recognizes holes that could potentially include threading and then asks you what kind of threaded hardware you want to use there.

Selecting both internal and external threads on part features is easy in our system. In your quote's Thread Assignment tab, you will notice a fully interactive model that allows you to select which threaded features are available. Each eligible feature is highlighted, and you can manually select threads.

If a thread you want isn't available, you may need to double-check the diameter of your features to make sure they are within the guidelines for threading. Note that while reviewing our threading charts, you can toggle between milled and turned options within each tab to review the availability of threads for each method of manufacturing. All threads need to be selected and saved before proceeding with an order. If you change your manufacturing process or material at any point, please check the Thread Assignment tab again as selections could change.

Many CAD packages allow you to display threaded features in a few different ways including tap drill, cosmetic thread, or by the major diameter of the thread. We suggest selecting the pilot diameter if it is designed at approximately 75% of the thread diameter.

On milled parts that require external threads, you must design the threads on your part as this would then be in our standard milling procedure that uses ball and flat end mills. As stated earlier, this wouldn't be the preferred method for producing threads as you may be required to perform a secondary process of chasing a cutting die over the threads to ensure the parts can be assembled correctly.

On turned parts, external threading improves greatly because the part is spinning on center and a sharp single-lip threading tool can produce a quality thread. The design of an external turned thread is like that of the internal hole. Remember that you must remove the threads so our software can digitally view the outside diameter to determine the type of thread needed.

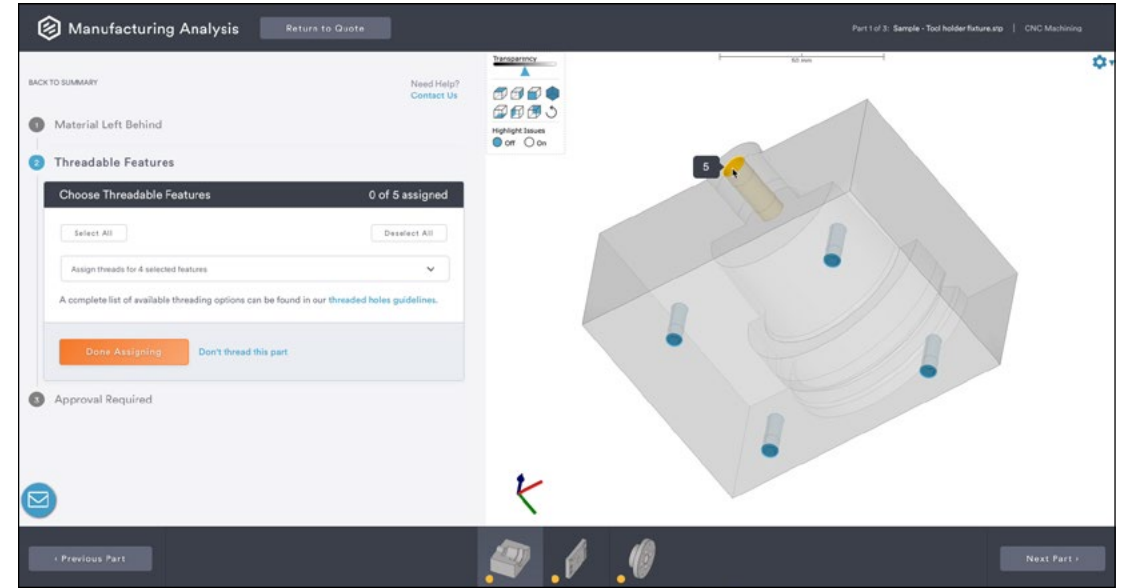

CAD File Formats

CAD files should be submitted in a file format other than .STL. We discourage uploading .STL file formats for machined parts because our software is unable to recognize features like pilot holes in that format. You should use a neutral file format such as .IGES or .STEP, if possible.



Post-processing Options

Perhaps you are wondering how to keep those 4140 steel parts you're ordering free of rust. Maybe you want your custom-made aluminum bicycle pedals to be a beautiful shade of blue or make threaded parts more durable. We can help you make **CNC machined parts** perform better, make them more wear- and corrosion-resistant, and improve their overall appearance, by using various finishing options through our precision machining offering.





Plating is Suitable for a Range of Materials

If you need a durable, corrosion- and wear-resistant finish, suitable for a wide variety of materials, look no further than nickel plating. Multiple types are available. At Protolabs, we offer the two most common. The first of these—bright nickel plating—is applied by negatively charging a workpiece after submersion in a tank of electrolyte. Current is applied to a series of nickel anodes within the tank, slowly releasing nickel ions that migrate through the solution and bond themselves to the part.

As its name implies, bright nickel is shiny. Depending on the amount of current applied and time spent in the tank, thickness can range from 0.00005 in. to 0.001 in. (0.0013mm to 0.0254mm). Chances are good that your old car's bumper is nickel-plated, as are the trim pieces on the dash, and the lighting fixtures in your house. All are covered under SAE AMS QQ N 290, although other standards apply. Electroless nickel plating eliminates the need for electrical contact and the subsequent electrical flow just described. For this reason, it's a favorite for high-volume plating of fasteners, fittings, and other hardware items. It is also very useful for hard-to-reach interior areas as it plates evenly across the part. It can be applied to almost any substrate: steel, stainless steel, aluminum, brass, and others. Also, it has excellent wear resistance compared to electroplated products.

Zinc, Tin, Gold, Silver, and Other Plating Options

The electroplating process can be applied to other metals, too. Exchange the nickel anodes for ones made of zinc, for example, and you're left with a plating that's great at protecting iron and steel from corrosion. Zinc should not, however, be used where parts will see temperatures greater than 500°F or in marine environments. See zinc coating ASTM B633-15 for additional information.

Due to its low cost, tin plating is also quite common. It is a soft, ductile, silvery-white metal that is not only corrosion-resistant but quite agreeable to soldering, so it is often used in the electronics industry for computer chassis and other components. Hot dip tin plating is also possible, which together with its electroplated alternative is described in MIL-T-10727 (MIL is a military specification coating).

Then there are gold and silver-plating options. From an electronics industry perspective, both are like tin, albeit with higher conductivity, solderability, and corrosion resistance, but with a higher price to match. And as evident from their use in the jewelry and dinnerware markets, they have an attractive appearance. These and other metals may require that a “nickel strike” is applied to the surface before plating to improve adhesion. Nickel plating provides excellent adhesion properties, so it is often used as an “undercoat” for other coatings.

Anodizing Looks Great

Anodizing is one of the most performed of all finishing options. Often referred to as a plating operation, it's technically an electrochemical conversion process that creates a thin oxide film on a metal part's surface.

For this discussion, we'll focus on aluminum anodizing as covered under standard MIL-A-8625, although anodizing of titanium and other metals is also possible. More on titanium shortly.

Two types of aluminum anodizing are available:

1. Type II sulfuric acid anodizing is known as decorative anodizing for its ability to absorb practically any color dye. That said, it offers an exceedingly durable and attractive finish up to 0.001 in. (0.0254mm) thick. Everything from carabiner hooks and flashlight handles to motorcycle parts and hydraulic valve bodies can be Type II anodized.
2. Beyond this is Type III hard anodizing, or hardcoat. Its color ranges from dark gray to bronze-like and is the thickest anodize available, adding as much as 0.003 in. (0.0762mm) to a part diameter and twice that to threads. Typically, the dimensional impact of most coatings and platings is fairly minimal, but hardcoat is just the opposite, something you want to remember when designing close-tolerance parts.

As mentioned, you can also anodize titanium components. Refer to standard Aerospace Material Specifications (AMS), especially AMS 2487 and AMS 2488 for additional details. In the medical industry, titanium medical devices are commonly anodized for color-coding purposes. In aerospace applications, titanium parts are anodized for increased corrosion resistance.

One quick reminder about the use of military (MIL) and aerospace (AMS) standards for anodizing and plating. If available, it's always best to reference these and other applicable specifications when ordering from us; otherwise, we might be left wondering what kind of anodizing, etc. you are requesting.



Anodizing	Hard Anodizing	Chromate
MIL-A-8625 Type II, Class 2 (Blk) MIL-A-8625 Type II, Class 1 (Clr)	MIL-A-8625 Type III, Class 2 (Blk)	MIL-DTL-5541 Type II, Class 3 (Clr)

The table above outlines the three types of aluminum anodizing and plating that are available through our quick-turn machining service.

Keep in Mind Sealing After Anodizing

With some exceptions, parts are usually sealed immediately after anodizing in a bath of nickel acetate or hot deionized water, closing off the material's microscopic pores. This process also generates different performance characteristics such as improved bonding and lubricity, depending on the type of anodizing and sealing process used.

For mission-critical parts, be sure to discuss your application requirements with one of our applications engineers before proceeding.

Powder Coating or Painting for Machining

Powder coating is another popular option. A staple of sheet metal fabricators (including Protolabs), think of it as dry paint that can be applied to any electrically conductive metal.

This option works by spraying a polymer-based colored powder through a special gun that charges the individual paint particles as they pass, making them stick to the surface. The powder-coated part is then placed into a hot oven to cure.

Powder coating is thicker than traditional wet paint and is more durable and fade resistant as well. It's also better for the environment—any leftover powder can be reclaimed and reused, and there are no smelly VOCs (volatile organic compounds) to contend with like there is with paint. For parts that can't resist the heat of the curing process, however, or ones that require a thinner coating than powder coat provides, paint is an excellent alternative.

In either case, we offer dozens of color choices and sheens. Paint and powder coat alike can be made glossy, flat, matte, or anything in between. Just let us know what you're looking for by using a Sherwin

Williams paint code or equivalent, as this provides us with all the information needed to get the job done right. Color matching is generally not available, though for paint we may be able to color match.

Passivation Also Protects Parts

Finally, no discussion of plating processes would be complete without some explanation of passivating, a process that “converts” the outer surface of metals to an exceedingly thin layer of oxide. It is similar in this respect to anodizing, but it's use is far more widespread, is applicable to a wide variety of metals, and is mostly performed without electricity.

Stainless steel is passivated to further reduce any chance of corrosion and remove any stray iron from machining operations.

Alloy steels, previously plated parts, and aluminum are subject to conversion coatings, like chem-film, and use phosphate or chromate to create the protective outer surface. These conversion coatings create an additional protective film for plated parts and some alloys. Chromate and other chem-film coatings for aluminum have good corrosion resistance and are a great base for paint.



[Grab a Surface Finish Guide](#)
Get an up-close look at your surface finish options for CNC machining at Protolabs.



Complex Features

CNC machining can create parts with incredible complexity and accuracy, and do it at a reasonable cost. The key is to design parts that adhere to certain rules for complex features.



Plating is Suitable for a Range of Materials

CNC machine tools gain greater capabilities every year. Live-tool lathes can mill various shapes and drill off-axis or radial holes, operations that would once have required a separate trip to the milling department. And some machining centers are equipped with indexing heads that support 5-axis machining, where multiple sides of a part can be completed in a single operation. This is good news for designer and engineer. Not only can extremely complex parts be produced, but it can be done with greater quality, lower cost, and shorter lead times.

As with our milling centers, CNC turning on high-speed lathes can complete many complex parts in a single operation. Live tooling and Y-axis capabilities mean it's possible to turn a bolt, mill the wrench flats, then drill a cross hole for a safety wire. More complex examples might include a hydraulic piston with alignment slots on one end, a fitting with spanner wrench holes on its face, or a shaft with an external keyway. In some cases, it's even possible to turn a part that's more orthogonal than it is round.

But that doesn't mean anything goes—certain machining rules still apply—and not following them can lead to expensive reworks and project delays. With that in mind, here are five elements to consider when designing complex parts.

True 5-Axis Machining

Protolabs' extensive machining capabilities include 5-axis mills, which allow for simultaneous movement on up to five machine axes while the cutting tool is engaged in the workpiece. Complex "swept surface" parts like boat propellers, orthopedic implants, and turbine blades can now be manufactured with fewer setups.

1 Hole Placement

The minimum size for on-axis and axial holes on Protolabs' CNC lathes is 0.040 in. (1mm), with a maximum depth of 6x the diameter. Radial holes (those drilled from the side of the part) should be at least 0.080 in. (2mm) in diameter. Holes that go all the way through turned or milled parts are usually okay (especially on hollow or tube-shaped parts), but depending on the part size, hole diameter, and material, the cutting tool might not have enough reach. Protolabs will machine from each side, when possible, but be sure to check your design analysis for potential constraints.

2 Deep Features

External grooves on a turned part cannot exceed 0.95 in. (24.1mm) in depth or be narrower than 0.047 in. (1.2mm). All other slot-like milled features generally read from the same playbook as drilled holes in terms of size, but a good rule of thumb is to keep the depth less than 6x the feature width. Also, be sure to leave at least 0.020 in. (0.5mm) wall thickness on the adjacent material. Large flats and other milled surfaces—mill or lathe—depend entirely on the part geometry relative to the available cutter size. Deep ribs and grooves can be challenging though, wherever they're made. It is possible to cut heat sink-like features on a turned or milled part, but this depends on the actual part geometry and available tools. Again, check your DFM analysis carefully, and don't be afraid to try our software, or contact an applications engineer.

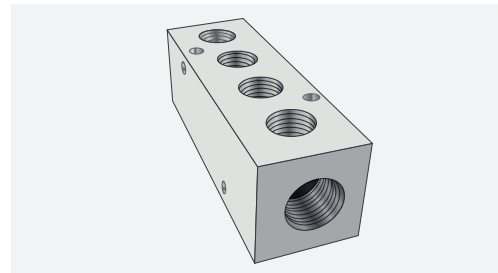

Adding Threaded Features: Designers frequently add threaded features to milled and turned parts. Threading options differ for each, so check [here](#) to ensure the right process is selected.

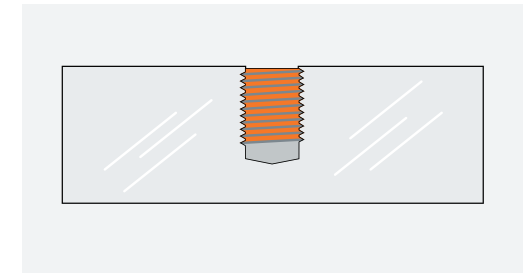

Coil Inserts: Considering threading for your machined part? You might also think about using an insert. Coil inserts (shown here), and key inserts, provide longer service life than bare threads, especially in soft materials like aluminum or plastic.

3 Better Threads

There's a great deal of overlap in threading capabilities between Protolabs' turning and milling centers. Protolabs can thread from #4-40 (M3 x 0.5) up to about 1/2-20 (M10 x 1.25) depending on the type of machine and the feature placement, although some exceptions exist. Check out the [threading options](#) for precise measurements and details. Also, remember what you read earlier about the proper way to model threads, and how this relates to internal vs. external and milled vs. turned part features. You might also think about using an insert. Coil and key inserts provide longer service life than bare threads, especially in soft materials like aluminum or plastic, and are easy for you to install.

4 Texting Can Be Costly

Complex aerospace and medical parts often require permanent marking of part numbers and company names. Recessed text may look nice, but it's also a very time-consuming machining operation and is downright prohibitive as production quantities rise. It's better to electrochemically etch or laser-mark parts, but if you must have engraved text, keep it short with simple, clean fonts. For soft metals and plastic, we recommend Arial Rounded MT font 14 point 0.3mm deep, and for hard metals opt for Arial Rounded MT font 22 point 0.3mm deep.

5 Radii: Watch the Corners

One common mistake on any machined part is the call out of sharp internal corners. For example, the turning tools typically used for finishing at Protolabs have a 0.016 in. (0.032mm) nose radius, so any mating parts should be designed with this in mind. Milling cutters go down to 0.040 in. (1mm), which means any pockets will contain internal corner radii a little more than half that. That's pretty sharp but remember that milling with a tool that small takes a long time, and will be limited to a pocket no more than 0.375 in. (9.52mm) deep. Instead, relieve internal corners or allow for as large an internal radius as possible on mating part designs.

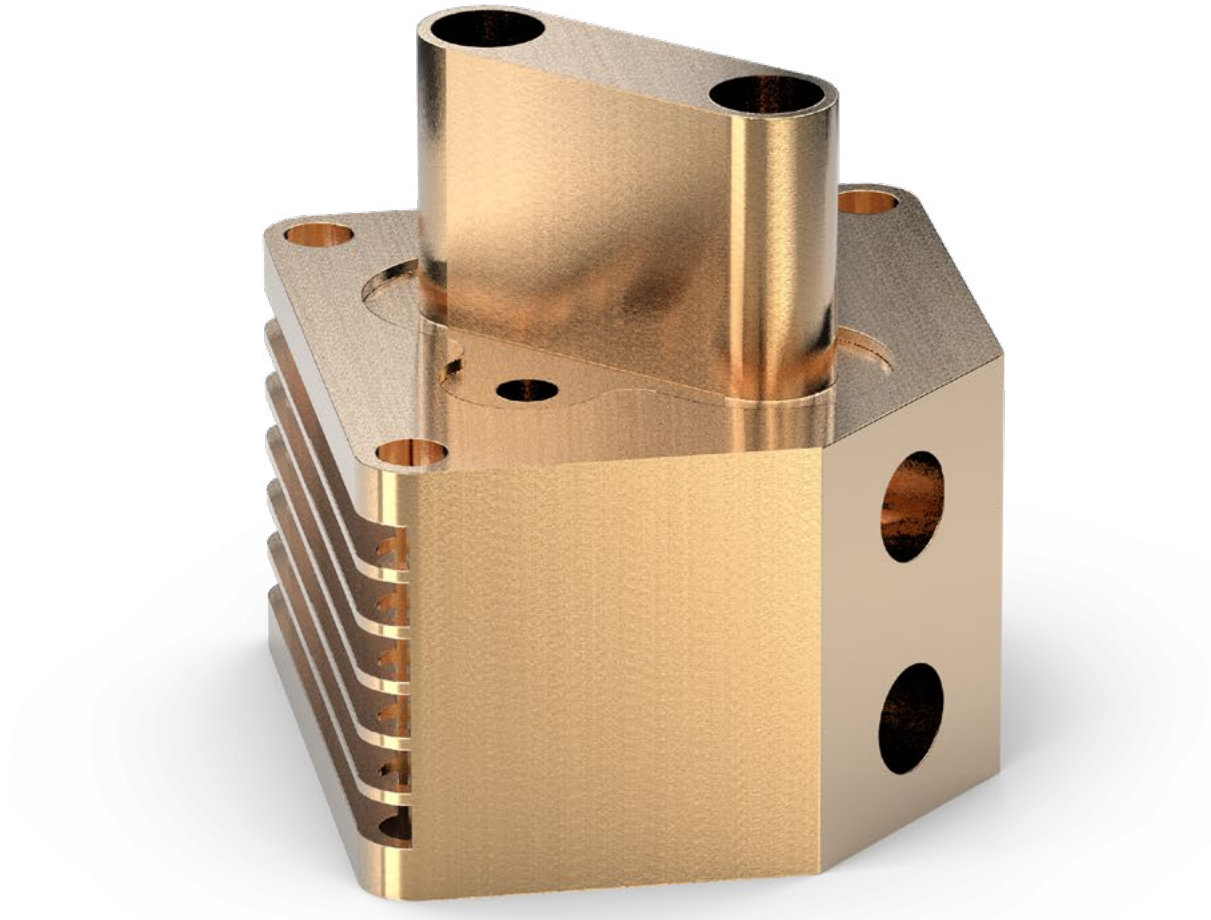



High-volume Machining

You already know that CNC machining at Protolabs is different from traditional manufacturing. Our process is fully automated—from CAD analysis to auto-toolpathing and digital inspections. This automation is what enables our speed, and you can take advantage of that speed when you're ready to move to higher volume production or simply need more than 15 prototypes.



“Protolabs’ qu
system basic
me how to de
injection-mold

— Mig
xxxx



Our massive machining capacity, which mills or turns parts in as fast as a day for rapid prototyping, can also be used for low-volume, end-use part production.

Machining for Higher-volume Needs Emerge

At Protolabs, we saw a way to fill the production-quantity gap, and also solve upfront and warehousing cost issues. Our massive machining capacity—with more than 500 CNC machines—can mill or turn parts in as fast as a day for rapid prototyping, or low-volume, end-use part production. This brings down machining costs without adding to lead time.

Production machining also helps ensure part quality with FAI reporting, Certificate of Compliance (CoC) documentation, and certifications such as ISO 9001 and AS9100.

Production machining doesn't offer the same economies of scale as molding or casting processes—especially at high-volume levels (think tens of thousands or millions). However, as machined production volume increases, cost per part goes down (think low-volume runs of dozens to a few thousand). Production machining also solves warehousing and inventory issues, providing you with supply chain flexibility by producing parts on-demand. In many cases, our customers find our machining service now allows them to use a single-source supplier from concept validation to short-run production.

Machining for Production Provides Supply Chain Flexibility

Plenty of machine shops out there can produce machined parts. We have several key advantages, particularly when you need production volumes of parts relatively quickly, or even varying quantities of parts. With our capacity, we can produce higher volumes of parts faster than other shops. Our end-to-end process begins with design analysis and quotes. Upload a CAD model to get your free analysis and quote within hours. If you need prototypes, request a quick-turn quote and get finished parts in as fast as one day. When you're ready for a higher volume of production parts, request a production quote and get parts in as few as five days. Our capacity, plus our large stock of materials, allows this speedy turnaround. The entire production process, from toolpath development to machining to finishing, is handled in-house for maximum speed, quality, and process control.

Related to flexible quantities, leveraging machining eliminates the high initial costs of mold or die production. Once the toolpath has been developed, you can order machined parts in lots as small as 15 pieces. On the other hand, if your ultimate production volume will be high enough to justify molding or casting, you can use machining for bridge production and take your product to market while you wait for production molds or dies to be made.

Production Machining of Plastics

At volumes of a thousand or fewer, machining plastics can be less expensive than injection molding. In addition, machining can produce parts that would be difficult to mold. These include parts with uneven wall thicknesses or with wall thicknesses over 0.150 in. (3.81mm), often needed for parts used as fixtures or wear plates.

The overall speed advantage of machining versus injection molding at modest production volumes increases as parts increase in size. Also, machining plastic eliminates sink, warp, and knit lines you find in molded parts, and machined parts don't require draft.

In some cases, engineers might consider 3D printing for these production volumes, but machined parts are cut from solid billet, which gives them several advantages over 3D-printed parts. Because they aren't layered, machined parts may have better physical integrity than printed parts. They can be cut from materials that cannot be used by 3D printers, and they can be machined to smoother finishes than printed parts.

Our earlier chapter on materials for machining provides a rundown of the materials we offer.

Production Machining of Metal

At low- to medium-production volumes, machining of end-use metal parts offers significant advantages over die casting. As with plastics, at appropriate volumes, [machining is faster and less expensive than casting](#).

While machining can begin turning out parts immediately, die casting requires the production of hardened steel tooling, which is a slow and costly process.

There are more metals that can be machined than can be die cast. And die casting leaves a rough surface like that found on cast iron cookware. Such surfaces can be smoothed by machining, but this is a time-consuming secondary process.

Die casting also does not produce as solid a finished product as the billet stock used in machining. Die cast metal can be porous, brittle, and subject to elongation. For these reasons, machining may still be preferable to casting even when casting has a cost advantage.

As mentioned before, our earlier chapter on materials for machining provides a rundown of the materials we offer.

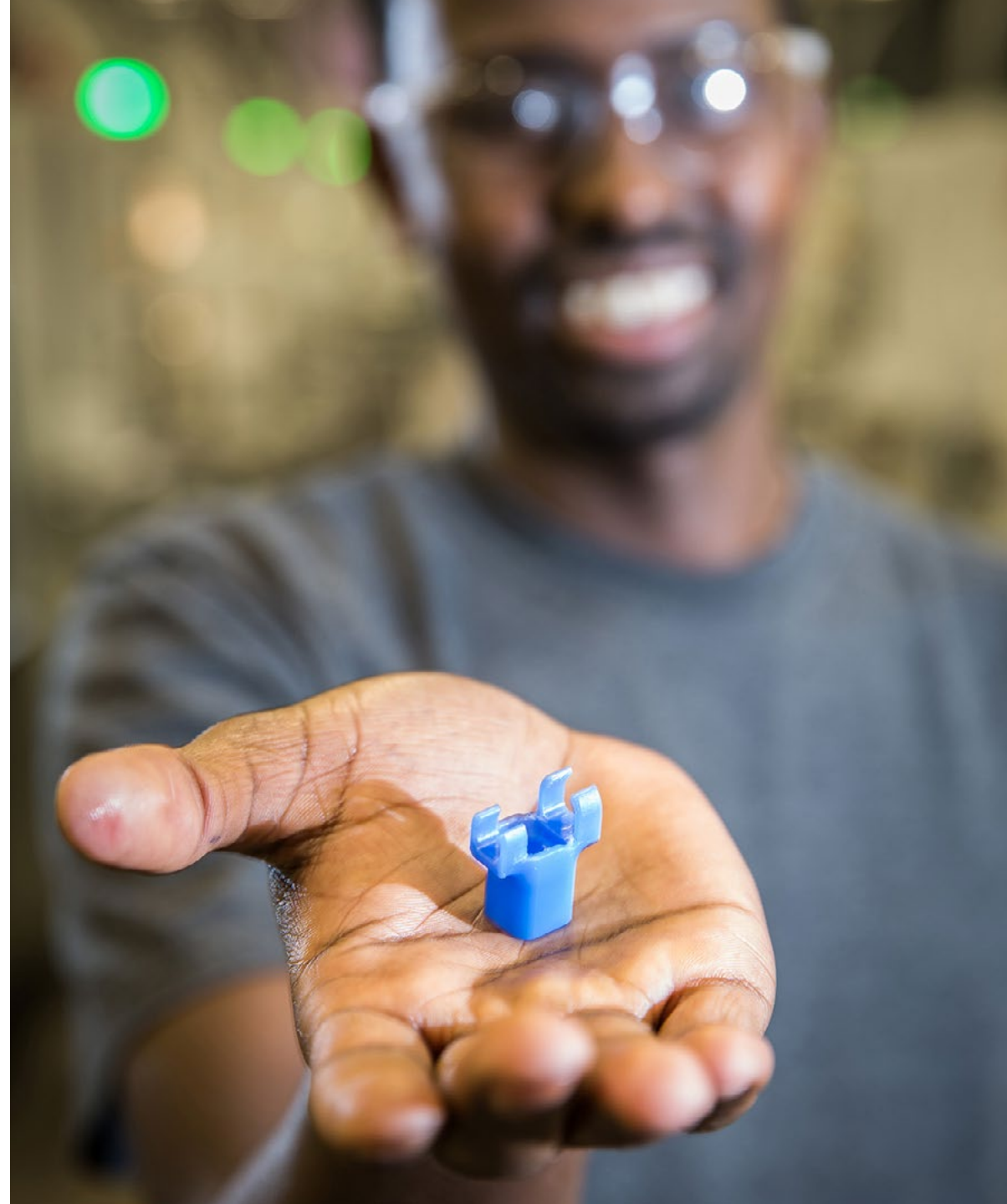

Why Protolabs for Custom CNC Machining?

Fast and Reliable Delivery

Quickly iterate part designs and accelerate product development with quick-turn parts. Our automated design analysis will help spot any difficult to machine features before your design is sent to the manufacturing floor, saving you from costly reworks further into the product development cycle.

Manufacturing Analysis and Online Quotes

When you upload your 3D CAD file to request a quote, we'll analyze your part geometry to identify any features that may be difficult to machine, such as tall, thin walls or holes that cannot be threaded.

Domestic Production and Support

Work with a trusted U.S.-based manufacturer and eliminate the risk of sending parts overseas. You can also call or email us at any time and we'll help with ordering parts, design feedback, material recommendations, and answer any questions.

Infinite Capacity

Eliminate downtime spent waiting for parts and safeguard in-house machining with on-demand relief and infinite manufacturing capacity.

Material Selection

We stock more than 40 engineering-grade plastic and metal materials that are suitable for various part applications and industries. Materials range from plastics like ABS, polycarbonate, nylon, and PEEK to aluminum, stainless steel, titanium, and copper.

If you have any questions regarding your quote or design, talk with our applications engineers who can help guide you through the process. We look forward to working with you on your next project!





Contact Us

5540 Pioneer Creek Dr.
Maple Plain, MN 55359
United States

P 877-479-3680

F 763-479-2679

E customerservice@protolabs.com



Get an interactive CNC machining quote
within hours that includes real-time pricing
and free design for manufacturability feedback.

