

7 Ways to Reduce Lead Times on CNC Machining

The way you design your custom parts will impact how fast machinists can produce them. Here are 7 tips for reducing the lead time on your next CNC machining run.

Tip 1

Use standard thread sizes

Designing parts that have holes with standard diameters will cut down on machining time, as they can be machined with standard drill bits. Also, it's much easier to machine larger threads.

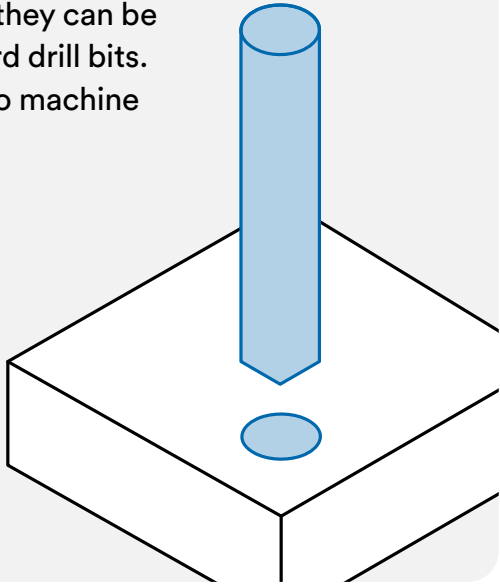

Tip 2

Add a large radii

Adding a large radius instead of sharp corners lets manufacturers use larger tools and remove more material in less time. This improves manufacturing speeds and cuts costs.

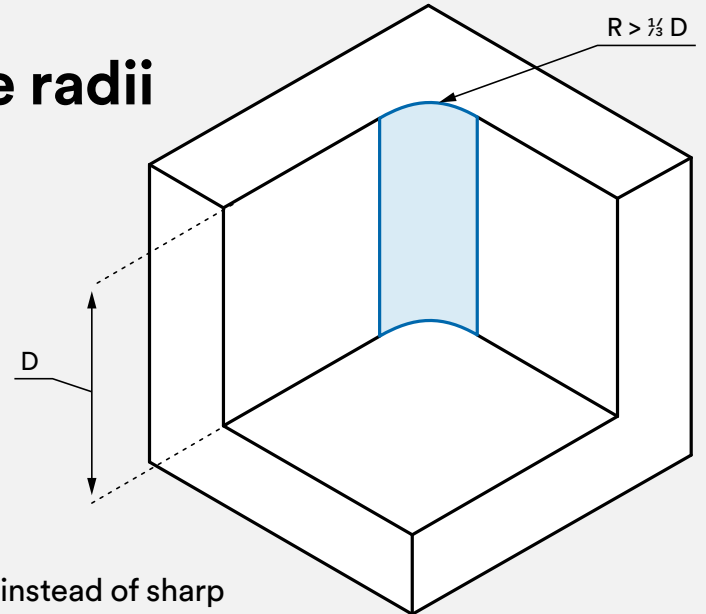

Tip 3

Loosen surface roughness constraints

Easing up on your surface roughness requirements lets manufacturers use larger tools and finish your part faster. If you choose as-machined/smooth machined parts (meaning no additional surface finishes), your part can be checked and shipped quickly.

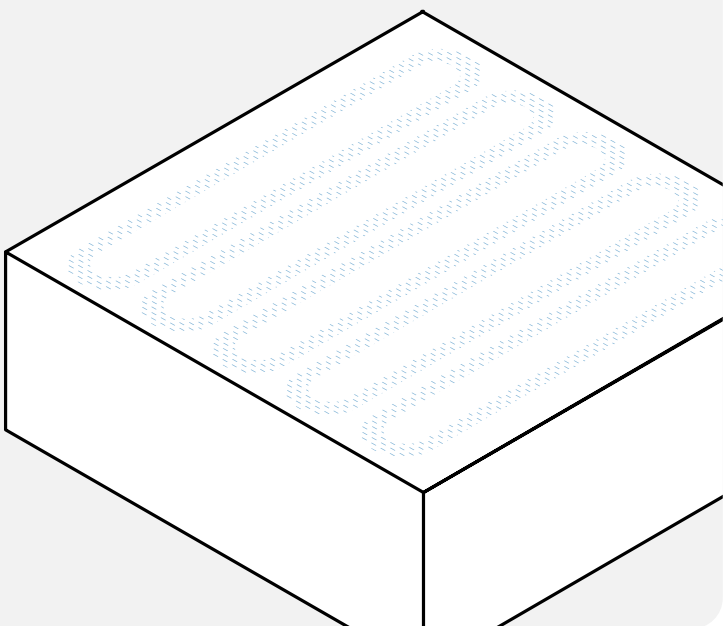

Tip 4

Remove tight tolerances

Select ISO 2768-m instead of ISO 2768-f and only use tight tolerances if this is critical for the part to function.

This gives manufacturers more machining freedom and reduces the number of passes per part.

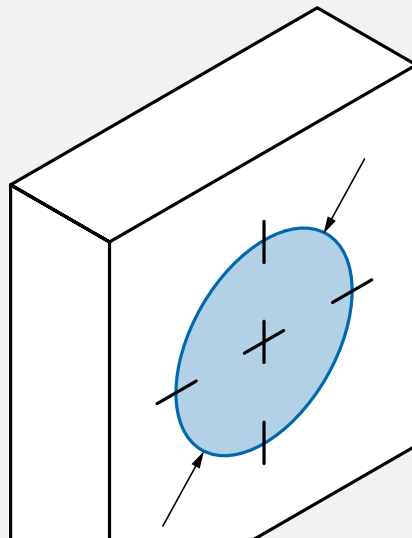

Tip 5

Use common materials

Choosing materials available in the quote builder helps Hubs send parts into production immediately. We can get custom materials, but that'll add to the procurement time.

Also, machining times are shorter for soft metals than for harder materials.

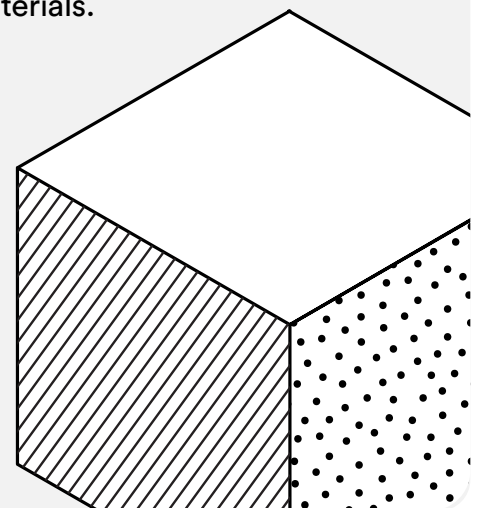

Tip 6

Avoid deep pockets

Reduce the depth of cavities up to 4 times their length (that's the largest dimension on the XY plane). This helps you avoid using longer, more delicate tools, as well as extra machining passes.

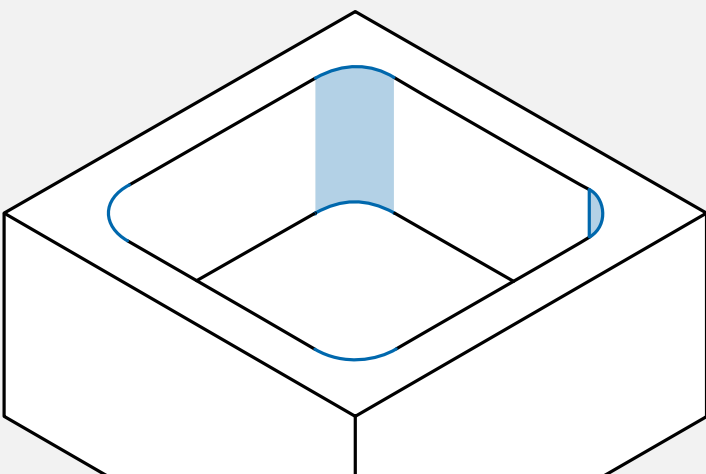

Tip 7

Avoid thin walls

Design your parts with a minimum wall thickness of 0.8 mm (0.03") for metals and 1.5 mm (0.06") for plastics.

Thin walls increase machining difficulty, which decreases the speed.

