



DESIGN ESSENTIALS

for Sheet Metal Fabrication



PROTOLABS
Manufacturing. Accelerated.

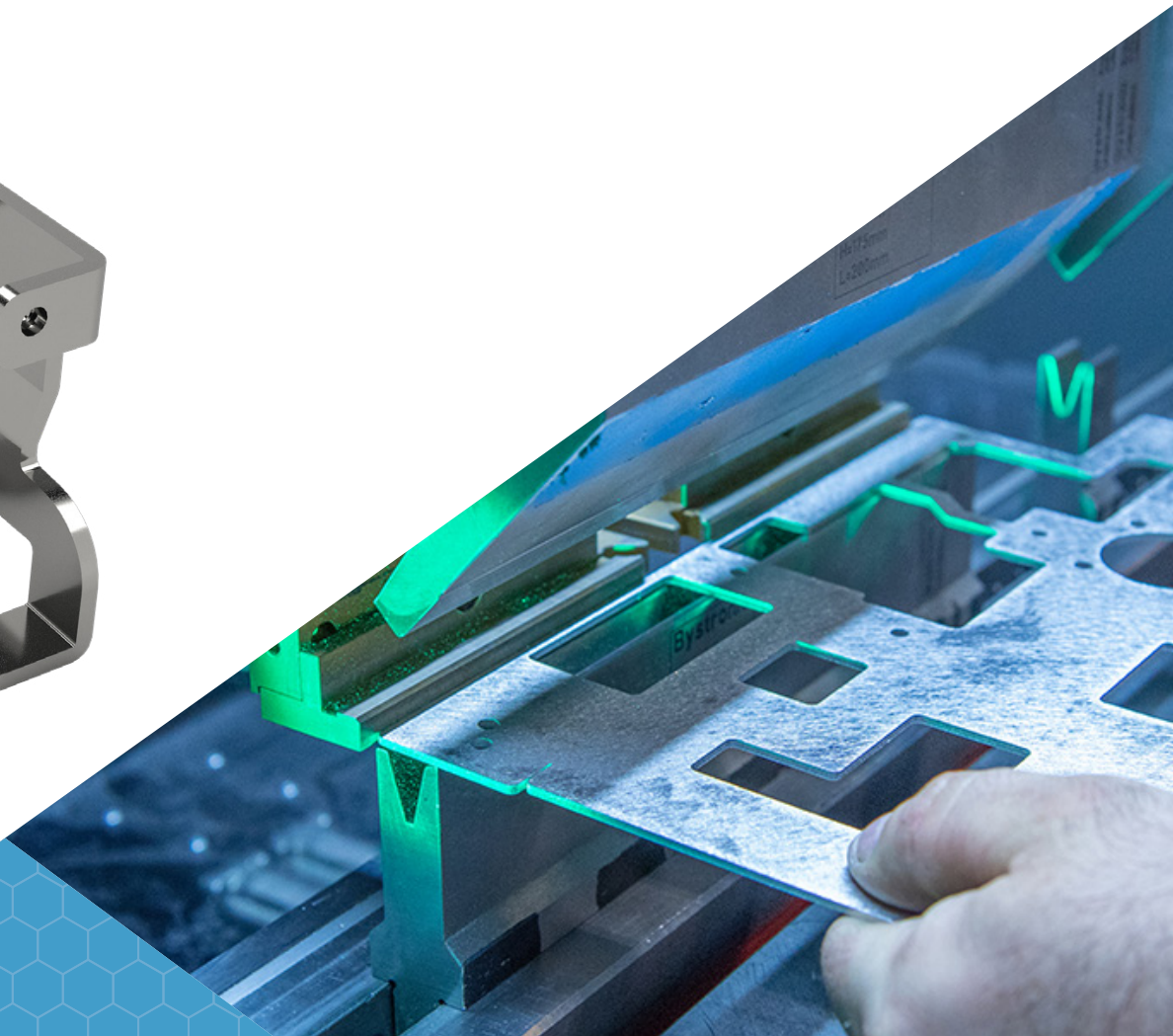
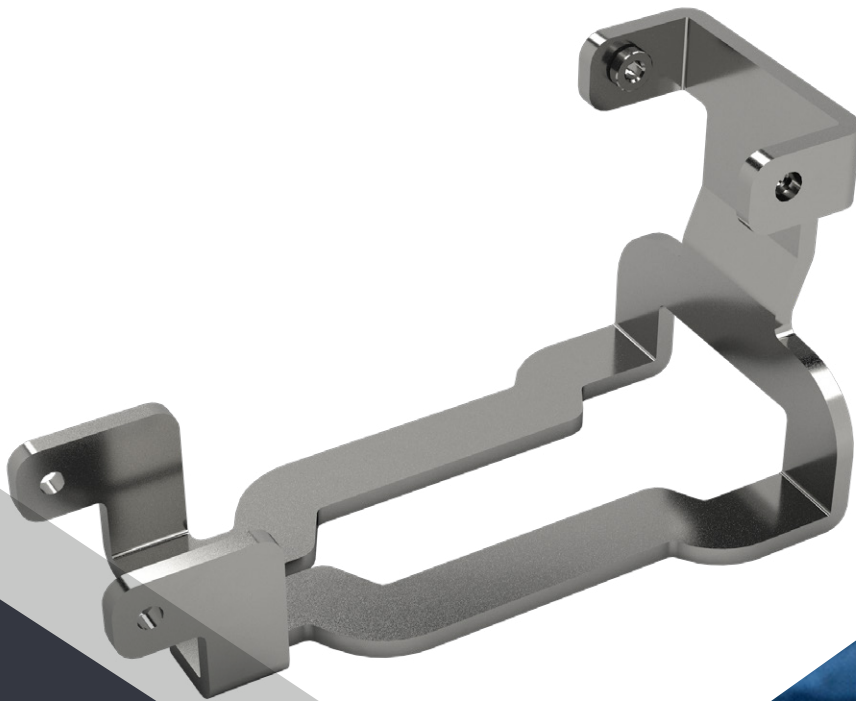

Contents

- 3 8 Rules for Converting Solid 3D Designs to Flat Sheet Metal
- 6 7 Ways to Improve Sheet Metal Parts
- 8 8 Mistakes to Avoid When Designing Parts
- 11 How to Efficiently Integrate Hardware into Part Design
- 13 Welding vs. Riveting
- 15 Finishing Touches with Plating, Powder Coating, and Silk Screening

Sheet metal is one of the most versatile materials in the manufacturing industry. It's made from steel, aluminum, brass, copper, tin, nickel, titanium, or precious metals. It ranges in thickness from wispy leaf through light foil to heavy plate. It takes a variety of forms: plain flat sheets, embossed, etched, ribbed, corrugated, and perforated. And its uses expand across many different industries including transportation, aerospace, appliance manufacturing, consumer electronics, industrial furniture, machinery, and more.

Designing parts for sheet metal can be challenging at times so we compiled our best tips to help you improve part design, avoid common mistakes, and help you best apply secondary finishing options for complete sheet metal parts.



HAVE A SHEET METAL PROJECT READY?

Upload your design online for an interactive quote within hours with real-time pricing based on quantity, finish, and lead time. Our experienced applications engineers are also available to provide practical design feedback on parts.

[GET A QUOTE](#)

8 Rules for Converting Solid 3D Designs to Flat Sheet Metal

Improve your sheet metal part design and reduce costs by sticking to these quick guidelines

To skilled sheet metal designers, the world is flat. Knowing that every part they make starts out as a thin, flat piece of metal certainly affects how they design their parts. Where it goes from there is determined by the designer's ability to envision that part after fabrication. It has to make sense as a sheet, while also functioning in three dimensions. That's the challenge.

Many designers prefer to work initially from a 3D design and then make the transition to sheet metal to create a flat design. For example, in SolidWorks, there are two tools to accomplish this. If you start with a solid 3D object, the Convert to Sheet Metal command is your friend. If you already have a formed part with uniform thickness, use Unfold to ensure that your part is sheet metal worthy. Both will get you partially there, but you still have to consider other elements of your part and how to get it to behave as a sheet metal flat. This design tip presumes that you're starting from a solid 3D object, as many designers do. Here are some basic rules to help get you started.

1

Comparing Sheet Metal Design Methods: Flat vs. Solid

Let's say you want to build a cube without a top. If you had designed it as a flat part, it would initially look more like a plus sign, with four outer squares surrounding a square in the center (see animation). The four outer squares would be folded upward to form the sides of the open-top box. All of those loose sides can be welded together later.

If you design a solid 3D cube, Convert to Sheet Metal gets you where you want to go. Start by modeling a cube that has uniform material thickness—it is sheet metal, after all. Doing this will save you some time and aggravation later. When you use Convert to Sheet Metal, you'll get a manufacturable sheet metal part. Easy, right? Needless to say, not all designs are this simple because of the nature of sheet metal.



An example of flat sheet metal design is this cube without a top, which would initially look more like a plus sign. The four outer squares would be folded upward to form the sides of the open-top box.

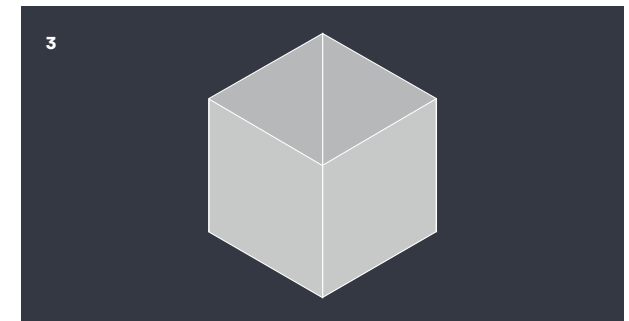
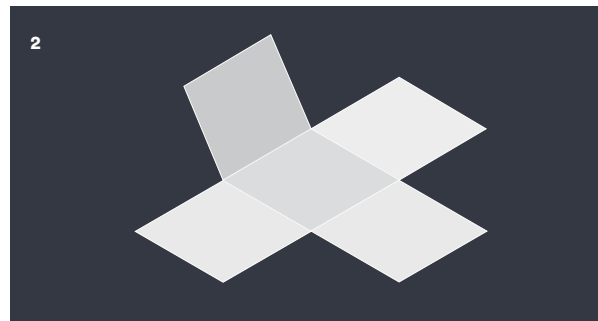

2

Rips and Seams

The great thing about the Convert to Sheet Metal command is that rips and seams are introduced into the model automatically. Rips are the processes that allow you to create seams, and are typically needed when designing certain kinds of formed parts. Without seams, you wouldn't have areas for the metal to unfold.

As you can imagine, when the flat part is put on a press brake and formed into a box shape, the edges between the sides will be parallel, but not connected. Your designs can indicate that all of the sides be welded together, to return the form to a solid box.

3

Bend Radii

When you bend sheet metal in a press brake, say to make a 90-degree corner for our box, you don't get a straight or sharp interior within that perpendicular bend. The tooling actually creates a slight curve at the exterior and interior bend point called a bend radius. Your designs should take this into account because it might affect the geometry of your part. The standard press brake tool has a radius of 0.030in. (0.762mm) that will produce a bend radius on the part that ranges between 0.030 in. and the material thickness. Modeling with a consistent 0.30 in. bend radius will help ensure your part can be manufactured as quickly and as cost-effective as possible. It's important to note that any time your design requires multiple setups, it could increase your part price and lead times. Adding those bend radius specifications in the model can also improve your lead times.

4

Bend Relief

Here's the tricky thing about that open-top box we're building. If you try to bend those sides up on a press brake, the surrounding metal will deform because you haven't designed in bend relief. It's nothing more than two small incisions, located on either side of a bend feature. Remember that each soon-to-be vertical side of the box is a flange and has to be able to move independently of the others.

Before unfolding your part in your design program, make small cuts in the corners where two sides meet. They should be at least 0.030 in. wide and locate them at least 0.015 in. (0.381mm) past the end of the bend radius on either side of the bend on your part. This will allow the metal to bend freely and the part to form properly.

You're probably thinking that this will create a small hole in that corner, and you're right. The good news is that the area impacted is very small. Welding will take care of that, if needed, to make your part stronger in that location.

5

Crashing Features

It's not just a great name for a punk band, it's a basic course in physics. Quantum mechanics says that you can't have the same particle in two places at once. In our box example, imagine that we incorporated a hole on one side with four flanges bent outward from the hole. The flanges are the same size as the hole. As you can guess, that won't work. Once you've designed a flange for a certain area, that metal is no longer available to be used elsewhere. Instead, you will want to create a second part (or multiple parts) that make up the box surrounding the hole. That one should be entirely separate from your primary part.

WARNING: Some design programs will allow you to create parts with no thickness. It's up to you to catch this issue in the unfolding phase or you may hear from your manufacturer, which could delay your overall order.

6

Beware of Non-Uniform Thickness

This one sounds pretty sensible, and that's because it is. Your designs must reflect the reality that sheet metal has a single thickness. If your sheet metal is 0.100 in. (2.54mm) thick, the entire part must have that thickness, too. Keep an eye out for differences such as this that will prevent your part from unfolding properly.

7

Surface Imports

Here's a tricky one. It's possible to design parts that are all surfaces. They look like solid parts, but are actually hollow and the surfaces have no material thickness. In the example here, this part actually consists of 10 surfaces—all six edges plus the four flat sides—each with a thickness of zero. So, this looks good visually but it won't unfold to sheet metal. The best solution is to always start with a solid body and maintain a uniform thickness throughout the whole design.

8

Feature Locations

With all sheet metal design, you have to consider where you place features relative to each other. What looks good as a solid part may not translate well, or even be possible, unfolded as a flat. So, it's important to visualize the fabrication process in your mind before assuming that your design will make sense. For example, if you want a hole near a bend and you locate these two features too close to one another, you would likely end up with a deformed part. The press brake will not be able to form the metal smoothly if there isn't a solid area where the forming tools are used.

The good news is that there are some simple, easy-to-follow rules you can use. Once you've determined your material thickness, always aim to keep a distance of four times that thickness in mind when locating holes. Also, make sure that the length of all hems and flanges is at least four times the material thickness. Using the 4T Rule of Thumb, you can avoid part failure during manufacturing.

Ultimately, designers who are more comfortable modeling 3D solid objects can still create manufacturable sheet metal designs. It just takes a few extra steps and the ability to flatten your perspective.

7 Ways to Improve Sheet Metal Parts

Consider material and finishing options along with design elements like bends, reliefs, holes, and slots when developing sheet metal components

Before diving into the details of sheet metal fabrication, recognize a basic fact of all sheet metal parts: They start out flat. And no matter how convoluted or complex their final shapes may be, the material thickness of those parts must be uniform throughout. So, for example, when designing a series of shelves to hold computer gear, you might be tempted to beef up the bottoms by making them thicker than the sides, but that's not how the sheet metal world works. Unless we weld two pieces together (which is possible, but at additional cost), material thickness should always be consistent. Aside from that, a variety of metals is available, including stainless steel, aluminum, cold-rolled and galvanized steel, and even copper and brass, in thicknesses ranging from 0.02 in. to 0.25 in. (depending on the alloy). Beyond sheet metal properties and available materials, here are eight ways to improve sheet metal parts.

1

Bending and Reliefs

One important element to keep consistent is the bend radius. Pick up any bent metal bracket or mount and look at the inside corners—see that little radius there? It's created by a punch and die set on a press brake. Protolabs can make bend radii all the way up to 1 in., but the standard tool set has a 0.030 in. punch, so plan for this for the lowest cost. As for the external corners, these are largely a factor of the material, its thickness, and the internal bend radii used.

Also, keep in mind that metal resists bending. To prevent cracks and meet a +/- 1-degree bend tolerance, Protolabs will place bend reliefs in strategic part locations—with a box shape, for example, the corners will be relieved slightly to allow the flanges to meet properly. The total amount of bend relief in this case will not exceed the bend radius plus the material thickness, and be no wider than 0.030 in.

On Z-shaped offset (1) features, try to keep all the bend radii the same, with 0.030 in. the preferred radius, and parallel planes should be at least two times the material thickness apart. With holes and slots (2), place at least 1/16 of an inch from the nearest wall or part edge for materials 0.036-in. thick or less, and 1/8-in. or more from the edge on everything else. Tabs (3) on either side of a notched feature should be at least 0.126 in. or two times the material thickness across (whichever is greater).

2

Offsets

Offsets are Z-shaped bends that might be used on brackets and clamps—the clips that hold your window screens in place are a good example. The same rules apply here as with any other bent part—try to keep all the bend radii the same, with 0.030 in. the preferred radius. Also, the parallel planes should be at least two times the material thickness apart, and you can expect Protolabs to maintain a tolerance of +/- 0.012 in. between the two features.

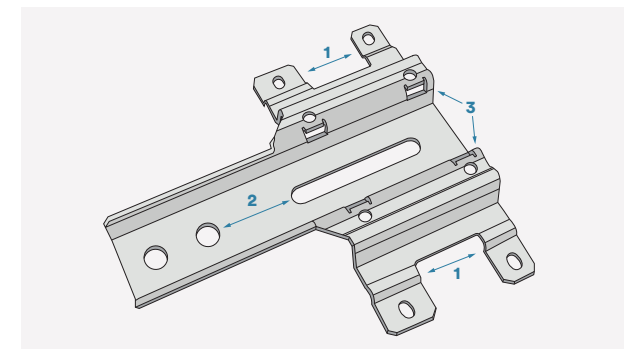

3

Hems

Bend a flange all the way over and you have a hem. They are used to strengthen part edges, or as a safety feature. An open hem is one that forms a U or C-shape and might be used to accept a pin for a hinge. Closed hems are basically flat, with the material folded over completely on itself. Closed hems are generally faster to manufacture and result in lower costs. The inside diameter of an open hem should be equal to or greater than the material thickness, and the “return length” in either case should be at least four times that.

4

Holes and Slots

These should be placed at least 1/16 of an inch from the nearest wall or part edge for materials 0.036-in. thick or less, and 1/8-in. or more from the edge on everything else. Hole and width tolerances will be +/- 0.005 in. unless otherwise specified. Check with the manufacturer if an insert will be used, as additional clearance may be required. If using the eRapid SOLIDWORKS plugin, all holes and slots should be a minimum of four times the material thickness from any bend or feature. Following these rules will help to keep costs down by avoiding potential post-processing steps.

Panel fasteners and other types of PEM hardware can be added to bolster sheet metal parts or provide threads for assembly.

5

Tabs and Notches

Sheet metal parts often require notches to accommodate a screw or other fastener. These should be at least the thickness of the material in width or wider and extend no more than five times the slot width into the workpiece. Similarly, the tabs on either side of a notched feature should be at least 0.126 in. or two times the material thickness across (whichever is greater) and again, be a maximum of five times the part thickness in length.

6

Inserts and Fasteners

Protolabs has plenty of experience with the use of inserts and fasteners in injection-molded parts. Sheet metal is no different, when nuts, standoffs, studs, and other types of PEM hardware are used to bolster parts or provide threads for assembly. Depending on the kind of plating the part will receive after fabrication, as well as the type of material it’s made of, when the insert is installed may vary based on hardware requirements.

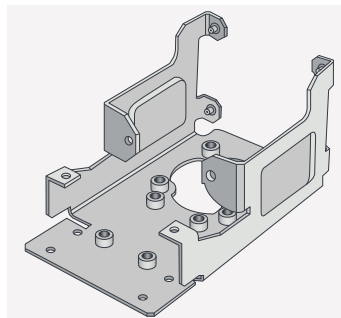

If this is of concern, check with one of the Protolabs experts before pushing the “accept” button.

7

Finishing Options

The plating services at Protolabs cover anodize, zinc, and chromate oxide. Powder coating and silk-screen services, using a handful of stock colors and special colors on request, are offered. There’s little to be aware of from a design perspective except to understand what each of those surface treatments does, which process(es) can be used with which material(s), and when to apply them (re-read the previous section if you’re planning to install hardware). Also, be aware that there is an additional charge for each of these services and lead times might be a bit longer.

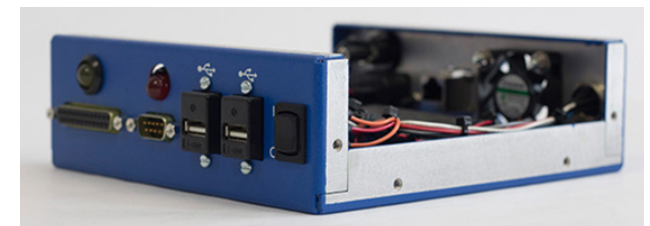
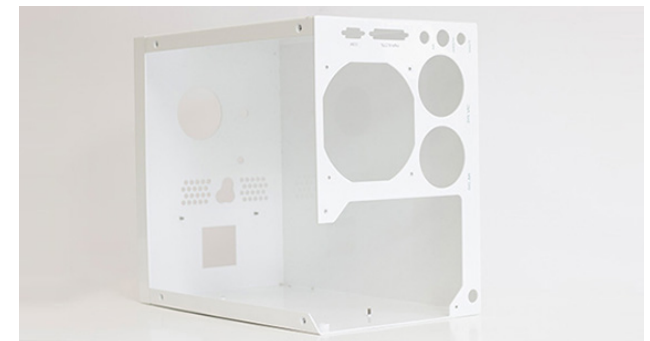

A computer chassis (top) and populated gaming box (bottom) each implemented a number of processes including forming, laser cutting, punching, hardware assembly, powder coating, and silk screening.

8 Mistakes to Avoid When Designing Sheet Metal Parts

Navigate through these common challenges when designing for sheet metal fabrication to improve part functionality and accelerate the manufacturing process

Some engineers have difficulties properly designing sheet metal parts for manufacturing. That's not you, of course (wink-wink). Still, we notice that there are certain issues that frequently appear in models that we've been asked to quote. With these issues in mind, we offer this list. It isn't exhaustive, but strap yourself in and see what many of your colleagues do wrong when they design for sheet metal and submit an RFQ.

1

Using Completed 3D Models of a Part with no Bends

This is probably the most basic issue we see. Sheet metal is flat and must be bent, formed, cut, and sometimes cajoled into its final shape. It's a very hands-on process. If you design your sheet metal part as a solid object, it's important that you send us a CAD file that appears folded, but shows where bends should go. Related to this, because the raw materials are single sheets of metal, the entire part must have the same material thickness throughout. For example, if you create a part that uses 0.125 in. (3.175mm) thick aluminum, your entire part will need to be that same thickness.

2

Placing Features too Close to Bend Lines

A quick way to create difficulties during manufacturing is to place holes, tabs, or other features too close to a bend. So, how close can you get? Just follow the 4T rule. Keep all features at least 4x material thickness away from bend lines. So, if your design tells us to use 0.050 in. (1.27mm) copper, give your feature at least 0.200 in. (5.08mm) of clearance. If you don't, the part will deform awkwardly in the press brake, and no one wants that.

3

Designing Perfectly Perpendicular Sheet Metal Corners

When you bend sheet metal in a press brake, the resulting bend doesn't form a perfect 90-degree sharp corner. Instead, the tool has a rounded tip that adds a radius to the bend. If you measure the length of that bent area and divide it by two, you'll get the bend radius, a figure that is defined by the tool that made it. If the size of that curve is important to you, make sure you specify it in your model.

The most common internal bend radius (and our standard tool) is 0.030 in. (0.762mm). Our standard tool will produce an inside bend radius that ranges between 0.030 in. and T.

Some designers like to get fancy and create different radii for each bend in a part. Want to save some money? Use the same radius for all of the bends. When your manufacturer doesn't have to change tooling that saves you on labor costs.

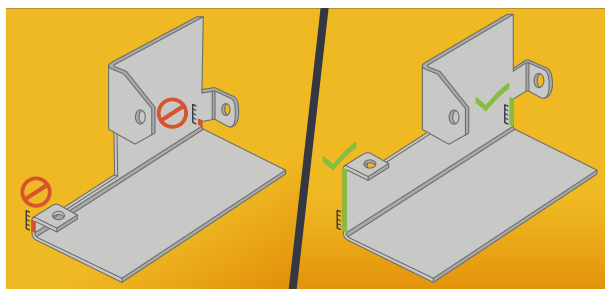

Carefully plan where you'll place holes, tabs, and other features and make sure they aren't placed too close to a bend, as seen in this example. How close can you get? Follow the 4T rule, keep all features at least four times the material thickness away from bend lines.

4

Forgetting to Include Detailed Hardware Specs in your CAD File

Do you know of anyone who wants longer lead times? Probably not. Always remember to let your manufacturer know what kind of hardware you want to use by including the details in your top level assembly information. Whether it's a self-clinching nut like CLS-440-2, flush-head stud like FHS-M5-15, or other hardware, this guarantees that you'll get exactly what you want placed in the location you expect it. To save yourself time and trouble, download and use the PEM clinch hardware models.

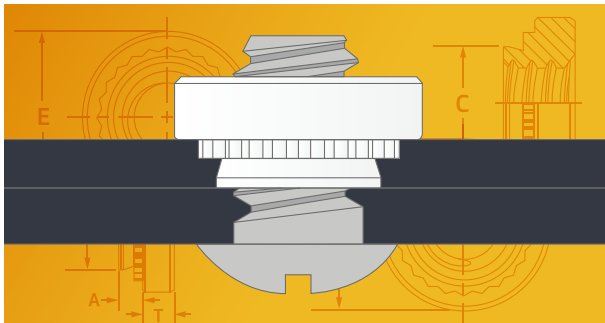

Including hardware details in your assembly information, like this self-clinching nut, will help you get what you want placed in the location of the part you expect it.

5

Picking the Wrong Finish (or Not Using One When You Need One)

Generally, finishes serve two purposes. They can protect your part or they can make it look better. Some do both. Aesthetic finishes—ones that focus on looks—don't focus on corrosion protection. Still, powder coating does offer some protection (unless a scratch reaches to the metal beneath). Silk screening, on the other hand, is used to add text and images to parts and offers no protection at all.

Chemical conversion finishes are meant to protect your parts by altering the properties of the outermost layers. For example, if you want to use steel in a corrosive environment, consider choosing galvanized or galvanized metal, which already has a protective zinc coating. Watch out, though! We can't weld galvanized steel due to the dangerous toxins it would give off. Instead, we can make the parts out of steel and add a zinc coating after welding.

Chromate conversion can give your part electrical connectivity and provides a primer layer to your part if you want to paint. Anodizing can add a pop of metallic color to your parts while also protecting them. Think of that colorful, small flashlight you own.

6

Selecting the Wrong Sheet Metal for the Job

Imagine making hundreds of parts out of unfinished steel that are destined for installation in a salty, marine environment. Amazingly, we've seen quotes that request just that. Save yourself the grief of the customer complaints you'll get when your parts corrode and consider these factors when selecting the right sheet metal:

- Expected wear on your part from daily use
- Corrosion protection
- Manufacturability
- Cosmetic appearance
- Mechanical properties (tensile strength, yield strength, ductility, etc.)
- Conductivity (for electrical applications)

7

Failing to Consider U-Channel Strength

When designing U channels, always think about the strength of the material you're using and how easily it can bend. At Protolabs, narrower doesn't work for us because of our tooling. If we had narrower tooling, we could manufacture narrower U channels. The bottom line is that it is best practice when working with us to maintain at least a 2:1 width-to-height ratio for your U channels. If you need a narrower channel, consider a welded or riveted assembly.

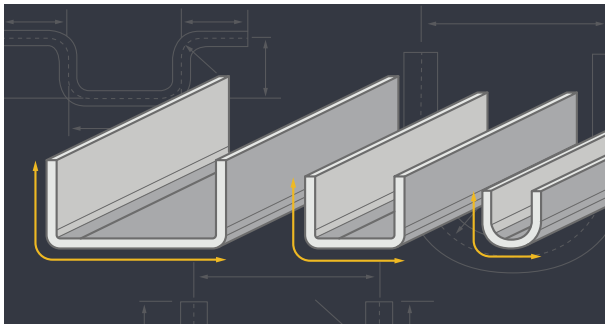

When designing U channels, consider the strength of the material you are using and how easily it can bend. Best practice is to maintain at least a 2:1 width-to-height ratio with U channels.

8

Designing Unrealistic Weld Requirements

Have you ever tried welding a seam inside a closed box? Nope? Neither have we. Make sure that your weld requirements are realistically achievable. It's important to remember that if a welding torch can't access a seam, the weld can't happen. We strongly recommend designing so all welds are done on the outside of the part.

Metal melts under high temperature, so you need material thicknesses that can manage the extreme heat. The minimal material thickness for welding is 0.040 in. (1.016mm) to ensure that the weld doesn't end up an unholy mess of melted metal.

Finally, in your models, always indicate the need for welds using a welding function or nomenclature. Never box corners to indicate welding.

How to Efficiently Integrate Hardware into Sheet Metal Part Design

Consider hardware material, placement, and other specifications to help optimize sheet metal parts

Light, strong sheet metal components are often fabricated and assembled into structures and products of all types and sizes: buildings, automotive parts, home appliances, airplane components, chassis, cabinets, cases, electrical enclosures, and so on. Your hardware choices are pivotal to final parts. They are often used to connect and bolster components or provide threads for assembly because sheet metal is thin, so it is difficult or impossible to thread holes in the metal. This is why these fasteners play a prime role, essentially becoming part of the sheet metal and providing a more robust thread or connection. Considering hardware specifications should be an important step in your design process.

This tip looks at four design elements to consider when incorporating hardware into sheet metal part design:

- Determining material compatibility of sheet metal and hardware
- Positioning the placement of hardware
- Choosing the right fasteners
- Timing the installation of hardware

Determining Material Compatibility of Sheet Metal and Hardware

A key early step in integrating nuts, pins, studs, and other connectors into your part design is to consider sheet metal and hardware compatibility—selecting the connector material to make sure it works with the type of sheet metal being used. This is where material hardness comes into play. In other words, how hard is your hardware?

The fastener material must be harder than the part material as they cannot be equivalent hardness, otherwise the fastener can be damaged in the insertion process or when parts are connected. If the sheet metal material is harder than the hardware material, the fastener won't flow and create the clinching action required for a secure installation. A secondary consideration in choosing the type of material for your fastener may be your intended finishing process for your part, if you wish to have the same finish on your fastener.

When integrating hardware into your part design, keep in mind that the connector (hardware) must have a hardness that is equal to or greater than the sheet metal material into which it is inserted, otherwise the connector can be damaged in the insertion process or when parts are connected. If the sheet metal material is harder than the hardware material, the hardware won't flow and create the clinching action required for a secure installation.

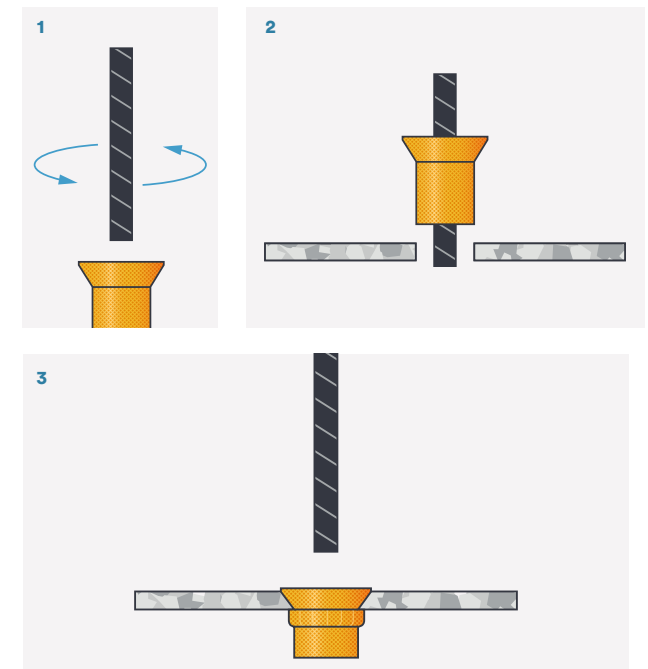

Choosing the Right Fasteners

Identify the class of PEM (or other) fasteners you need based on function. Typically, the choices for sheet metal applications are:

- Nuts of various sorts into which you'll insert screws
- Studs in several categories onto which a nut can be fastened
- Threaded and unthreaded standoffs to provide spacing between connected parts

In your designs, standard in-stock hardware parts are definitely the way to go. We keep in stock most of the hardware you are likely to need. By designing around in-stock parts, you can shorten your lead time. Check out our table of [available sheet metal hardware by type](#).

You'll also want to determine the thread you'll be using for the connection and choose the appropriate thread code if you are using a PEM connector.



Positioning the Placement of Hardware

When designing your sheet metal part, where you position the fasteners is also a key decision in order to ensure that the placement won't affect the structural integrity of your part or compromise the hardware's installation. To maintain this integrity—and for ease of insertion—fasteners must maintain a minimum distance from the edges of parts, from bends, and from other connectors. If they are installed too close to the edge, the material will displace and bulge. If it is too close to a feature like a bend there will be difficulty ensuring the hardware is installed straight. Accordingly, placement is an important piece to not overlook as you design, and will help ensure that your part will be manufacturable and hold up over time.

This location issue also comes into play when placing holes and slots certain distances from part edges, folds, and bends. One consideration on placing holes for PEM fasteners is the size of the arbor press used to install the holes. The installation tools are typically 0.5 inches in diameter. Holes must be positioned such that the press won't impinge, as mentioned, on a fold or bend when installing the connector. In other words, if the installation tool can't be flush with the part, we can't install to manufacturer specifications.

Where you position the connecting fasteners on a sheet metal part is a key decision to help ensure the placement doesn't affect the structural integrity of the part. At left, hardware was placed too close to the part's edges, which created bulges. At right, the hardware is positioned far enough away from the edges so that the part will be manufacturable and hold up over time.

Additionally, if you are using PEM hardware, you'll also need to keep in mind the shank depth of the desired fastener. This is specific to the thickness of the sheet metal into which the fastener will be inserted. For best performance, it is recommended you choose the maximum shank length for your sheet metal thickness.

Hardware is Tricky

Ultimately, to effectively use hardware—whether they are PEM fasteners or others fasteners—you'll need to make several key decisions. These include material compatibility, selecting the right fasteners for your part, location of the fasteners, and the timing of hardware installation.

Welding vs. Riveting: Fusing Sheet Metal Parts

Knowing the strengths and drawbacks of each method creates stronger, longer lasting parts

If you're designing a part that requires you to fuse two pieces of sheet metal together, it's time to think about welding vs. riveting. Knowing the strengths and drawbacks of each method will get you a stronger, longer lasting part.

Welding: Advantages

We all know that welding is cool to watch (with special shields or goggles on, of course) and welds have a nice surface finish once they are ground and polished. For designers, welding also offers a lot of freedom because you don't have to design flanges to accommodate a rivet or spot weld, and geometry can be more dynamic. So, the bottom line is that welding offers what is essentially a permanent bond between two surfaces.



For fusing pieces of sheet metal together, welding is often a go-to method because it offers what is essentially a permanent bond between two surfaces.

Riveting: Advantages

One of the biggest advantages of riveting is that your two parts don't have to be made of the same type of material. Aluminum to steel? No worries. Stainless to galvanized? All good! The most commonly used rivets in precision sheet metal assemblies and part joints are POP rivets, also known as blind rivets. As long as you can access one side of the hole with the rivet installation tool, you're all set. Best of all, riveting is fast. Rivets are easy to install and they don't require any post-installation cleanup work. The process is even faster than using screws and nuts to hold a joint together, as long as the joint is intended to be permanent.



A major advantage of riveting is that your two parts don't have to be made of the same type of material.

Welding: Limitations

Welding can look great, but it can also be time consuming. Doing it right requires considerable skill, which can add significant cost and lead time to a part or assembly. One other limitation is that the heat required to weld can distort and discolor metal surfaces, especially if they are thin. Finally, welding requires surface preparation and post-weld cleanup, adding to lead times and requiring a skilled welder to do it right.

Riveting: Limitations

Rivets are quick, but if you want to make your connection invisible, they aren't the way to go. No matter what you do, your rivets will be in plain sight. Even countersunk rivets will protrude somewhat from the surface. Some designers may see this as a no-go for aesthetic reasons.

With rivets, you also have to consider the hole location for two reasons. To achieve structural integrity, you need the hole to be a good distance in from the edge of your part. You also need enough space to accommodate your rivet tool, especially when it comes to interior placement. In some cases, you may have to add material to the assembly to strengthen your riveted connection.

Last, but not least, generally, riveting is not as strong as welding. If you need the two parts to be capable of withstanding forces that draw the pieces apart, riveted joints will be more likely to fail compared to a properly welded joint.

Welding vs. Riveting: Which to Use?

In the end, the decision to use riveting vs. welding is based on your needs, both aesthetically and structurally. This chart can help you decide.

	Aesthetics	Strength	Speed	Varied Part Materials	Cost
WELDING	X	X			
RIVETING			X	X	X

Finishing Touches with Plating, Powder Coating, and Silk Screening

Consider the environment that sheet metal will live in, its required cosmetic appearance, and final part assembly

There's a lot more to creating custom sheet metal parts than just cutting and bending a slab of metal. For each part you design, you have to consider the metal's material qualities and the environment in which the part will be installed. Corrosion could destroy a part in short order if you choose the wrong metal with the wrong protective plating.

A second consideration is what the final product looks like. Some people like the rustic or industrial look of bare metal, but sometimes you want your parts to pop with color. For branding purposes, you might be considering adding your logo or additional text or images must be included on your part.

Typically, sheet metal parts attach to other parts as part of an assembly. Making that happen is the job of specialized hardware.

Finishes for Protection: Chemical Conversion Coatings

When iron and water mix to form the dreaded compound iron oxide (FeO_2 , for you chemists out there), you get rust. Because iron is present in most sheet metal, given the right conditions your part will slowly dissolve into powder. Not good. But treated with the right chemical coatings, sheet metals can be serviceable for years without showing extensive signs of corrosion.

“In the end, correct finishing specifications are the key component of the plating process,” said Michael Garner, Protolabs Materials Supervisor. “You have to think about the chemistry of the part because coatings don't necessarily work on all metal surfaces. Choosing carefully will help you avoid delays in manufacture.”

Here are some of the most common types of chemical conversions that can keep your parts intact for years to come.

Zinc

This element is key to the coating that protects galvanized and galvanized metals. Zinc protects the metal beneath, limiting—and even preventing—rust. In this process, zinc chemically bonds with steel, sacrificing itself when exposed to the elements, especially water, saving the core of the part. Even if the coating is mildly damaged, the presence of zinc will limit corrosive effects on your part. The visual end-result of this chemical treatment is that galvanized metals have a spangled quality of silver tones and grays. Galvanized metals have a smooth, matte-like finish that can be painted later. One thing to be aware of is that these types of metals cannot be welded because they release hazardous toxins. Instead, we can weld cold rolled steel (CRS) and then have it plated with zinc afterward.

If you need zinc plating applied after a part has been created, that can be done either through an acid or alkaline process. Acid zinc is quickly applied and covers the part well, but it doesn't always spread uniformly. On the other hand, the alkaline zinc process takes longer because it requires electroplating. An electrical current is run through a zinc bath, causing zinc ions to flow and attach to your core material. The advantage of this process is that metals treated in an alkaline zinc bath have a coating that is more uniform and more accepting of stretching and forming.

Chromate Conversion

Zinc isn't the only chemical that helps avoid corrosion. Chromate conversion, adds the bonus of electrical conductivity to aluminum, zinc, tin, silver, magnesium, or cadmium parts. The finish ends up clear to yellow in quality. There are different treatments used to coat different metals, but ultimately chromate can act as a protective primer of sorts that allows you to paint a surface. Note that steel and iron-based metals cannot be chromated directly—you would first need to pretreat with zinc.

Anodizing

This method works by placing a sheet of aluminum in an acid bath filled with electrolytes. When you run electricity through the tank, the surface of the aluminum will hook up with oxygen atoms in the electrolyte to form aluminum oxide (Al₂O₃). This would happen normally in the real world, but doing it in a controlled environment quickly yields an attractive, smooth, corrosion-resistant surface. You may like the finish just like that, but because the surface is porous, you can also add color and an additional sealant. One thing to remember is that while anodizing works well with aluminum, it does not with CRS.



Anodizing can be used to add a cosmetic, corrosion-resistant surface to sheet metal parts. It works best for aluminum components and is available in clear and black (pictured above).

Passivation

Another way to protect the surface integrity of your part is to passivate the surface. Passivation is any surface conversion or plating that makes the part more resistant to corrosion and environmental impact. One of the most interesting things about this process is that no one really knows how it works. Chemical passivation of stainless steel uses an acid solution to dissolve free irons from the surface of the material helping to reduce the tendency for it to oxidize/corrode. This process also effectively cleans the part. Passivation of stainless steel does not build up on the part.

Powder Coating

We offer 30 in-stock powder coat colors, but we can order additional ones based on Pantone® color matching system, though that may increase lead time.

Looking Sharp: Sheet Metal Coatings for Aesthetics

Chemical coatings are great at protecting your parts, but maybe you have something more colorful in mind? If so, you should consider one of these two popular metal finishing processes: powder coat or silk screening.

Powder Coating

The name of the process says it all. With powder coating, the objective is to cover as little or as much of an object as you want with a pigmented powder. It seems simple, but there are several steps to make it work properly.

First, your part must be cleaned so the powder can adhere to it. Then, it is attached to an electrically charged wire—typically made of copper. The powdered pigments spray out of the end of a nozzle at your part, powered by a compressor. Because the powder is electrostatic, it loves to stick to charged surfaces. A skilled finisher targets the spray to evenly coat the part. At this point the powder can still come off easily, so your part must be handled carefully.

Once the part has been coated, it goes into a 400° F oven to bake for about 20 minutes. The thermoset polymer in the powder melts and hardens in the oven. In the end, the powder coating leaves your part with a smooth, even surface.



Silk Screening

Let's say you want to add your logo or some explanatory information to your part. Silk screening is the way to go. You provide the design and text you want transferred. We then use a process that incorporates the design file you provide onto a very thin, fine-mesh screen, upon which we put large blob of ink. When pressure is applied to the layer of ink, it can flow through the screen and onto your part, limited to the areas where you want it to appear. Once transferred, we apply heat to the ink, bonding it to your part. Silk screening works well on raw metal or coated surfaces, and just as with powder coat, we can match your desired Pantone color.

Powder coating is a fast solution for aesthetic parts that require a smooth surface finish and a specific color. Typically, the process adds about 0.002 in. – 0.004 in. of powder coat build up to both sides of the part.

Forming a Final Part

Aesthetics are one of the most critical aspects of custom sheet metal parts. A highly cosmetic part or assembly of parts can be the difference between product success or failure. At Protolabs, we offer a range of sheet metal finishing options that can address a variety of needs, both cosmetic and functional.